

# Identifikacija nabitih delcev

Peter Križan

*University of Ljubljana and J. Stefan Institute*



**University  
of Ljubljana**

**“Jožef Stefan”  
Institute**

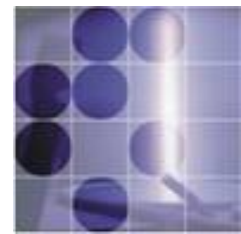

# Why particle ID?

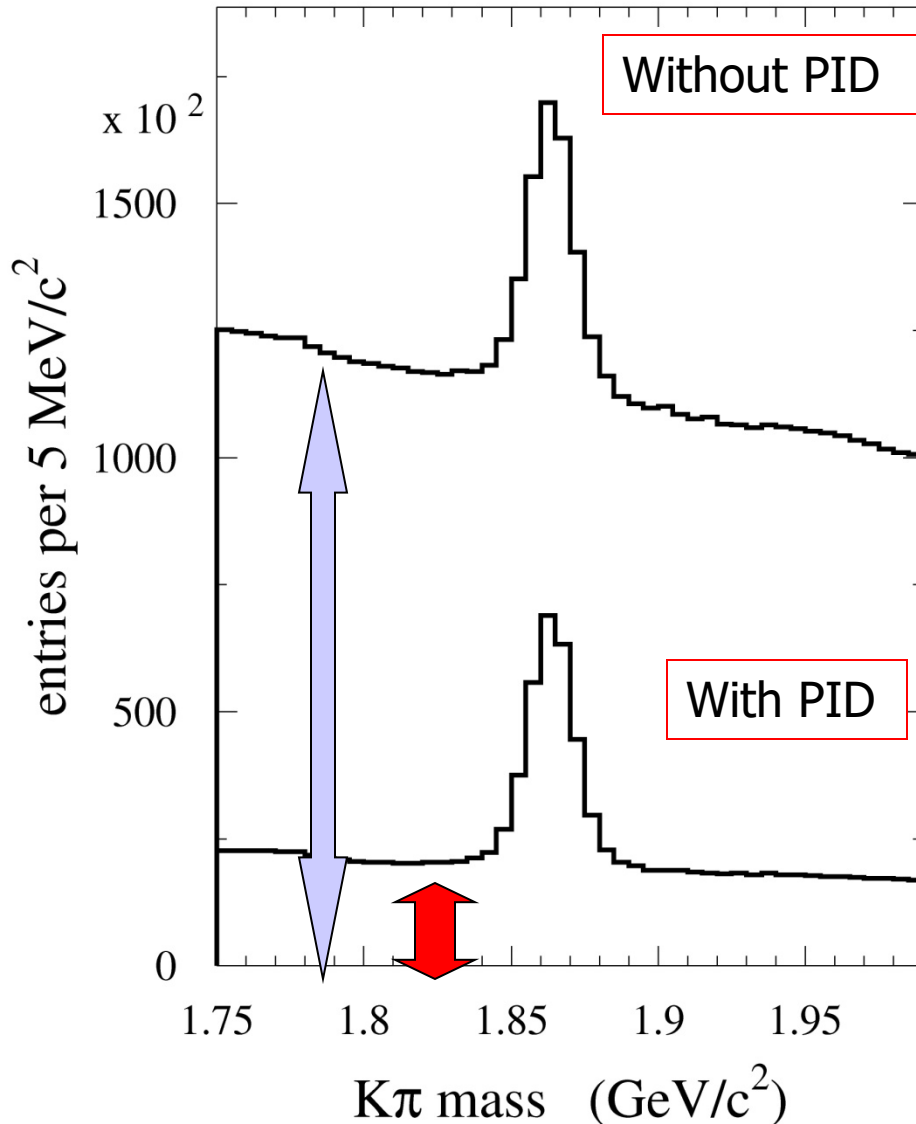

## Example 1: B factory

Particle identification reduces the fraction of wrong Kπ combinations (combinatorial background) by ~5x

Searching for a D meson decay to Kπ: From measured kaon and pion tracks calculate the invariant mass of the system (i= K,π):

$$Mc^2 = \sqrt{(\sum E_i)^2 - (\sum \vec{p}_i)^2 c^2}$$

The candidates for the D→Kπ decay show up as a peak in the distribution on a background of false combinations ("combinatorial").

# Why particle ID?

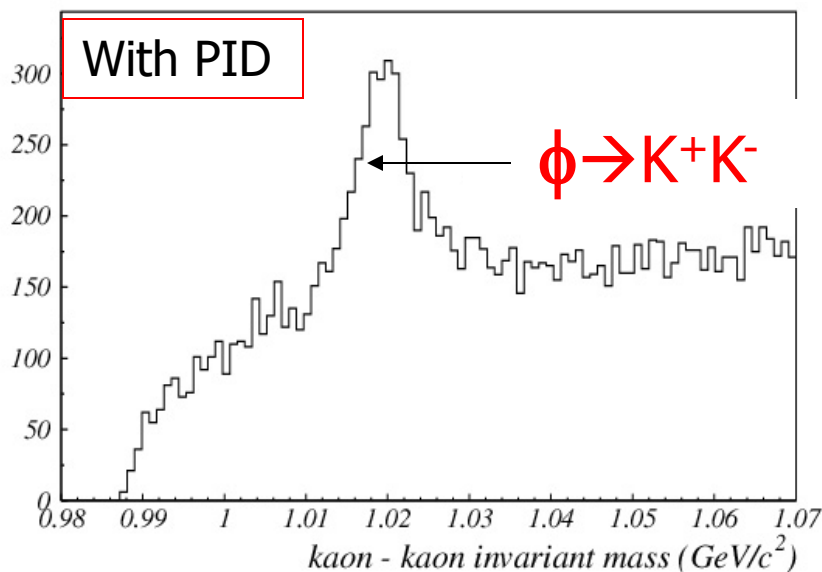
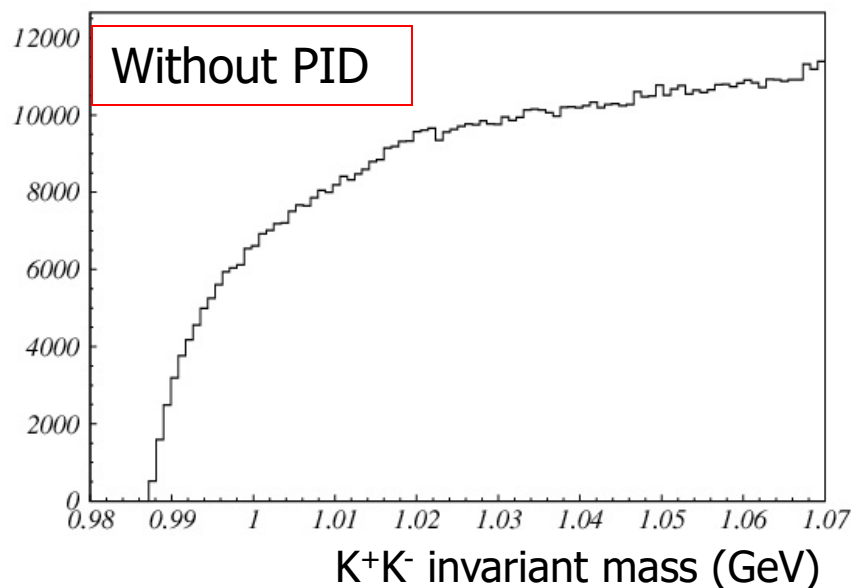

Example 2: HERA-B

K<sup>+</sup>K<sup>-</sup> invariant mass.

The inclusive  $\phi \rightarrow K^+K^-$  decay only becomes visible after particle identification is taken into account.

# Why particle ID?

Particle identification at B factories (Belle and BaBar):  
was essential for the observation of **CP violation in the B**  
meson system.

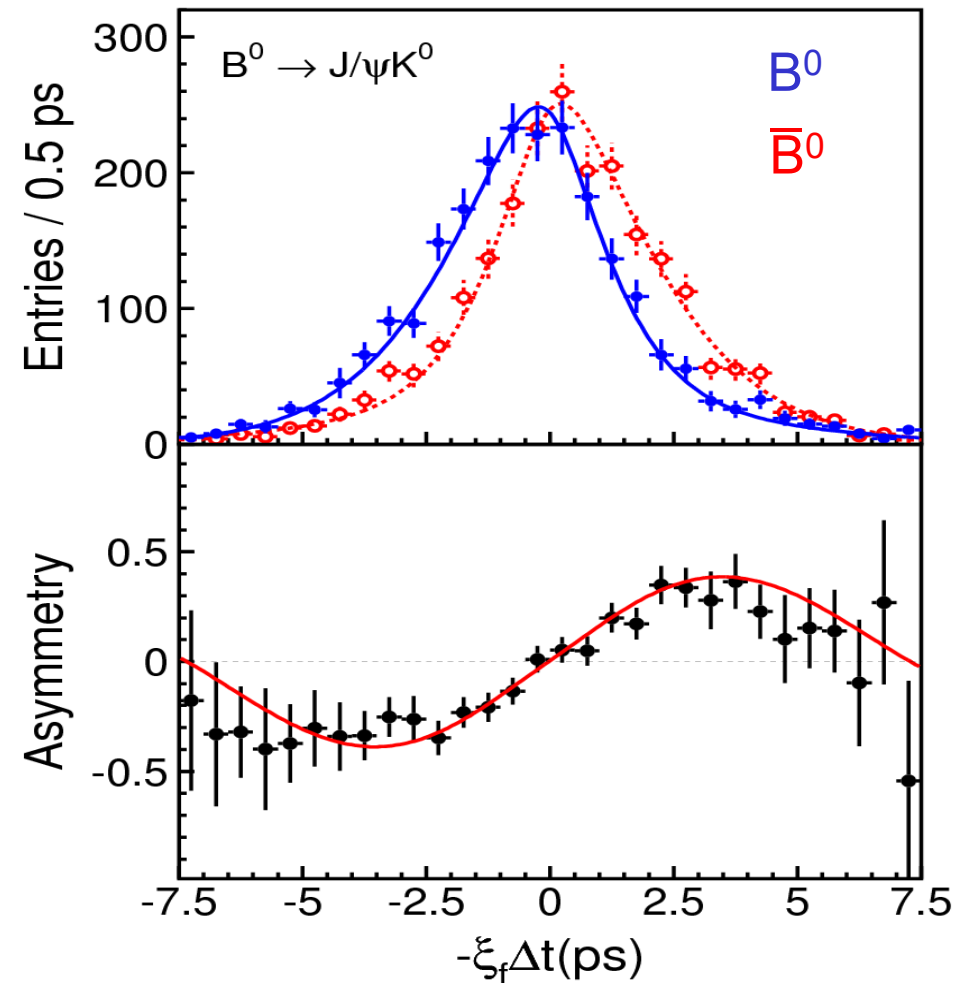

$B^0$  and its **anti-particle**  
**decay differently** to the  
same final state  $J/\psi K^0$

Flavour of the B: from decay  
products of the other B:  
charge of the kaon, electron,  
muon

→ **particle ID is compulsory**

# Example: Belle

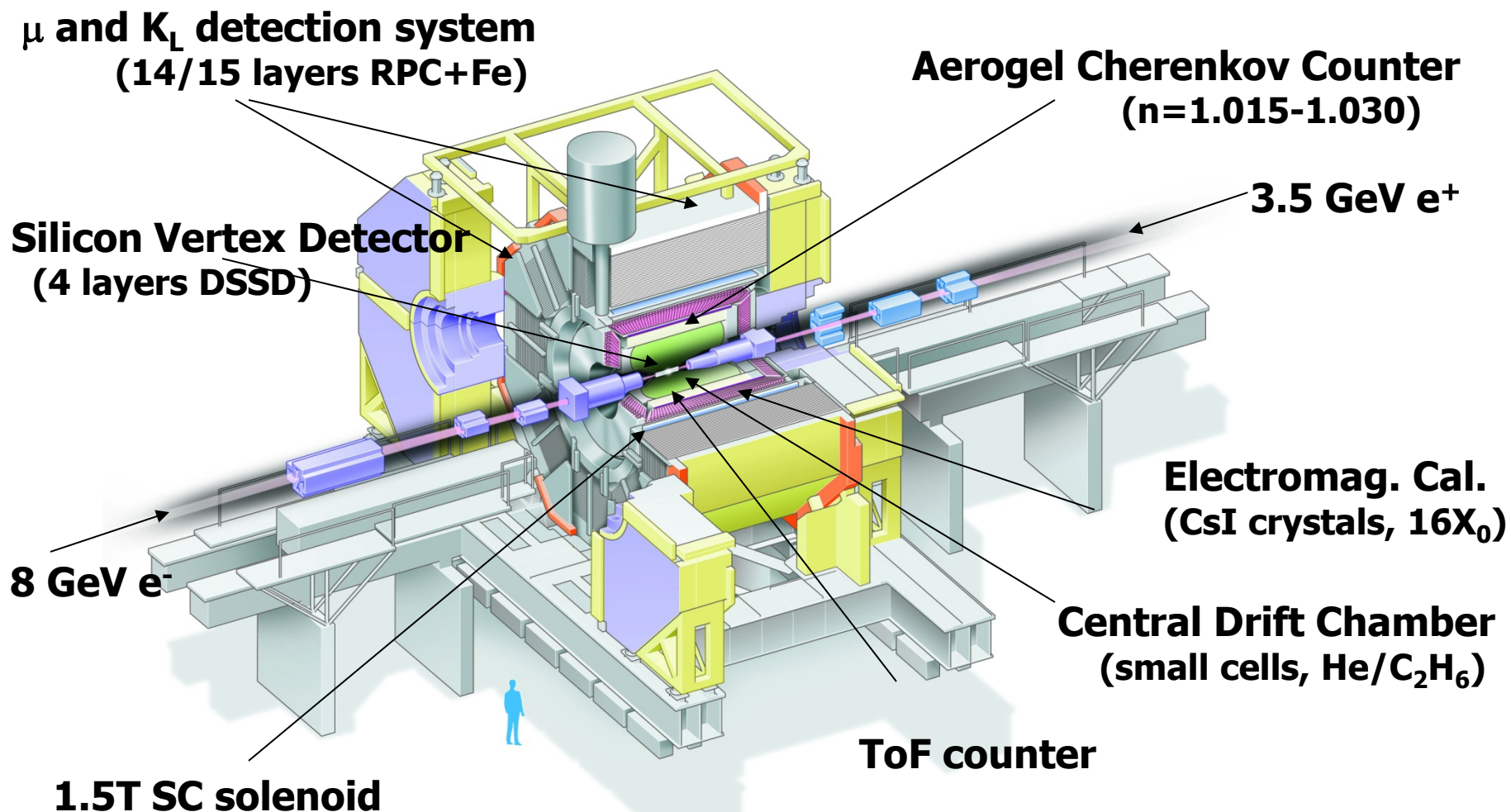

# Particle identification systems in Belle

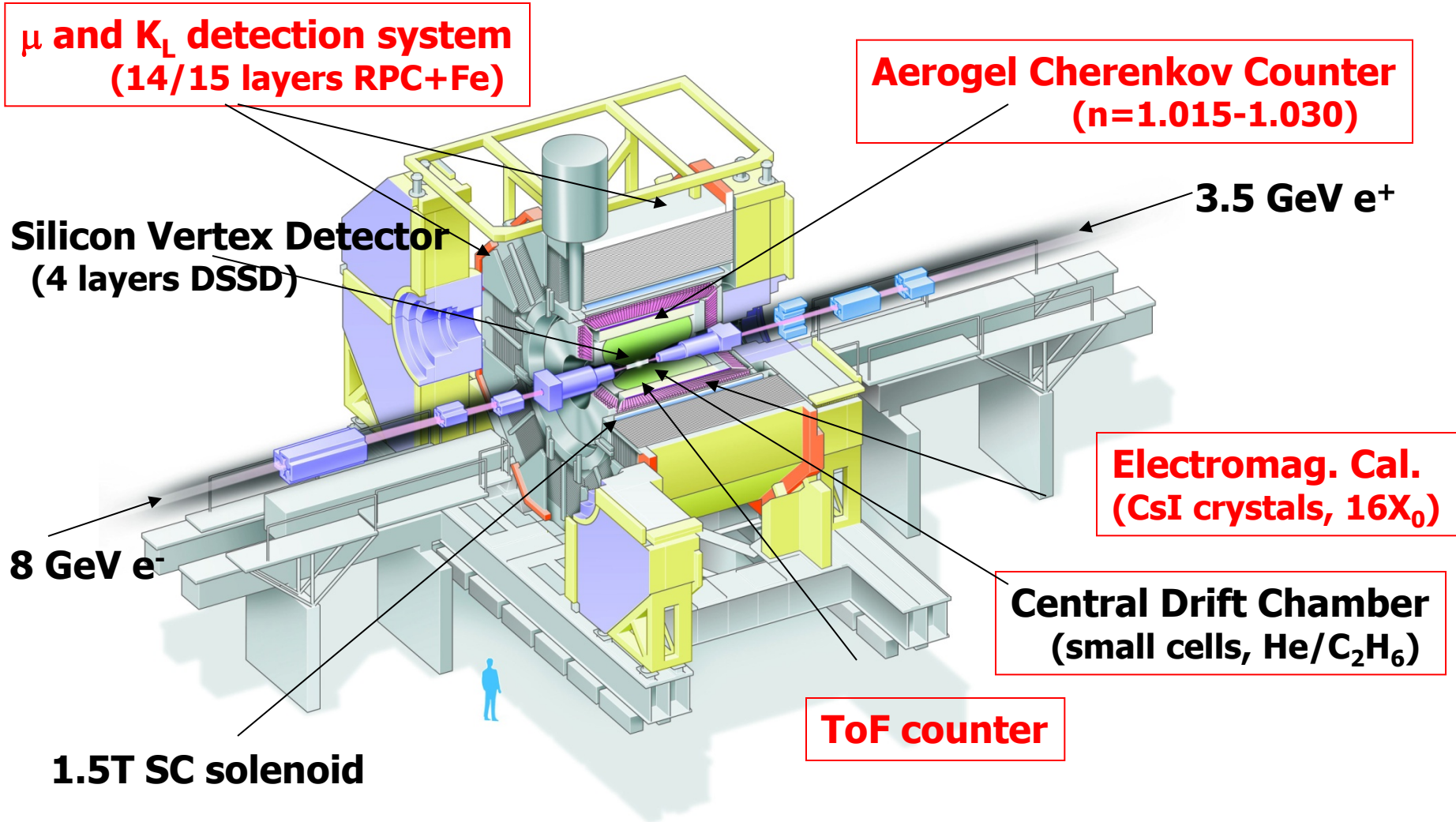

# Identification of charged particles

---

Particles are identified by their **mass** or by the **way they interact**.

Determination of **mass**: from the relation between momentum and velocity,  $p = \gamma m v$  ( $p$  is known - radius of curvature in magnetic field)

→ Measure velocity by:

- time of flight
- ionisation losses  $dE/dx$
- Cherenkov photon angle (and/or yield)
- transition radiation

Mainly used for the identification of hadrons.

Identification through **interaction**: electrons and muons  
→ calorimeters, muon systems

# Efficiency and purity in particle identification

Efficiency and purity are tightly coupled!

Two examples:

particle type 1    type 2

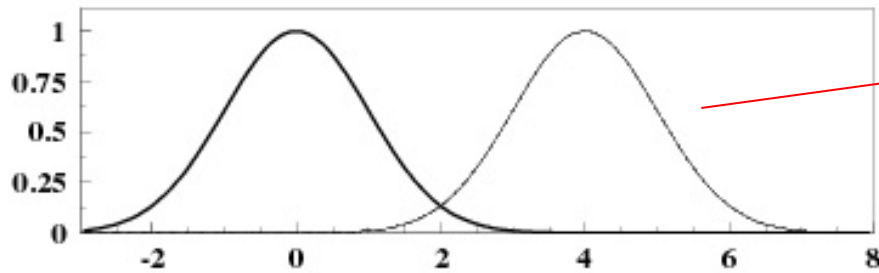
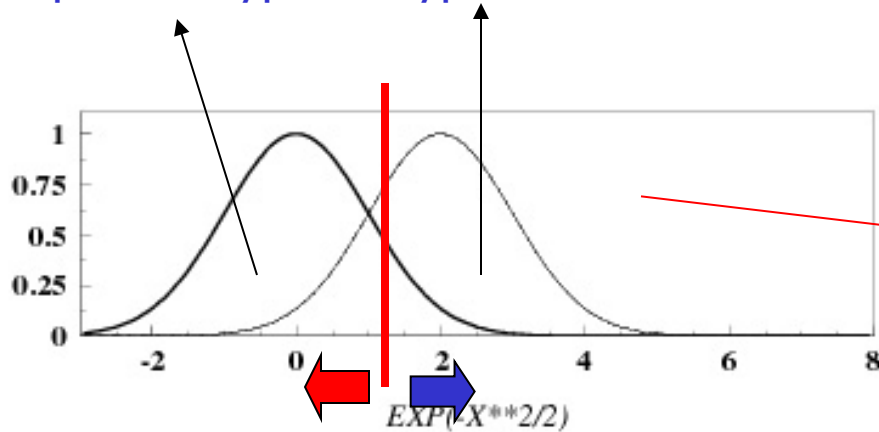

some discriminating variable

eff. vs fake probability

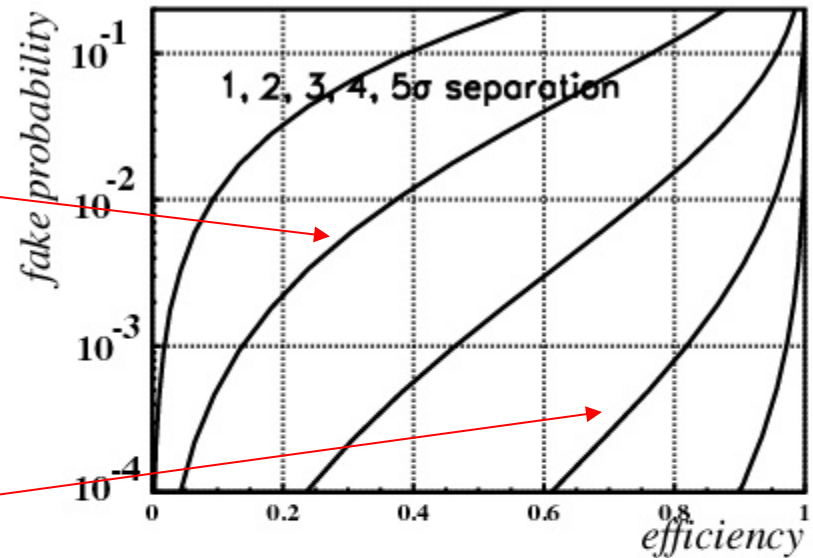

# Time-of-flight measurement (TOF)

Measure time difference over a known distance, determine velocity

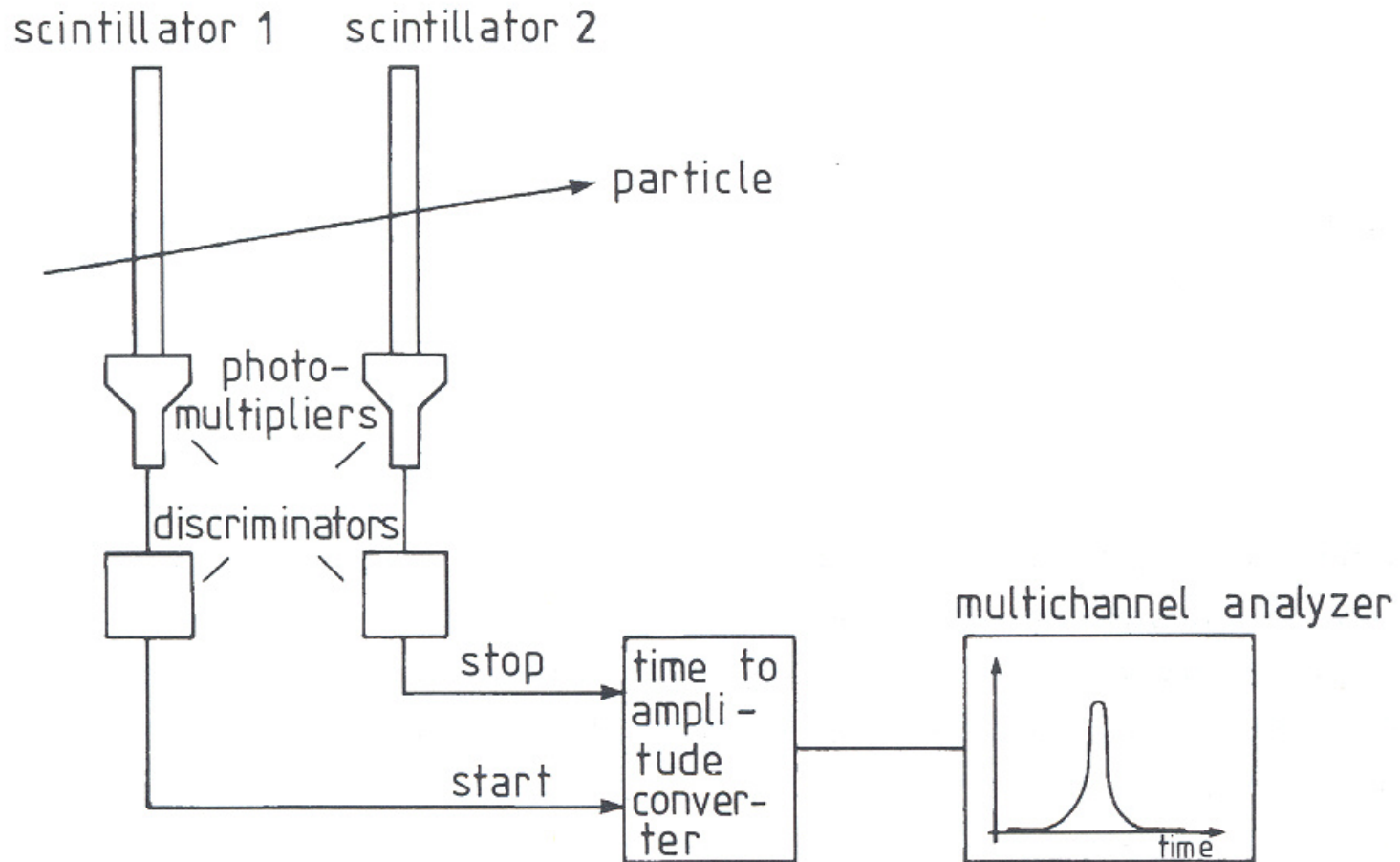

Fig. 6.5. Working principle of time-of-flight measurement.

# Time-of-flight measurement 2

Required resolution, example:

$\pi/K$  difference at 1 GeV/c: 300ps

For a  $3\sigma$  separation need  
 $\sigma(\text{TOF})=100\text{ps}$

Resolution contributions:

- PMT: transient time spread (TTS)
- Path length variation
- Momentum uncertainty
- Decay time of the scintillator

Time difference between two particle species for path length=1m

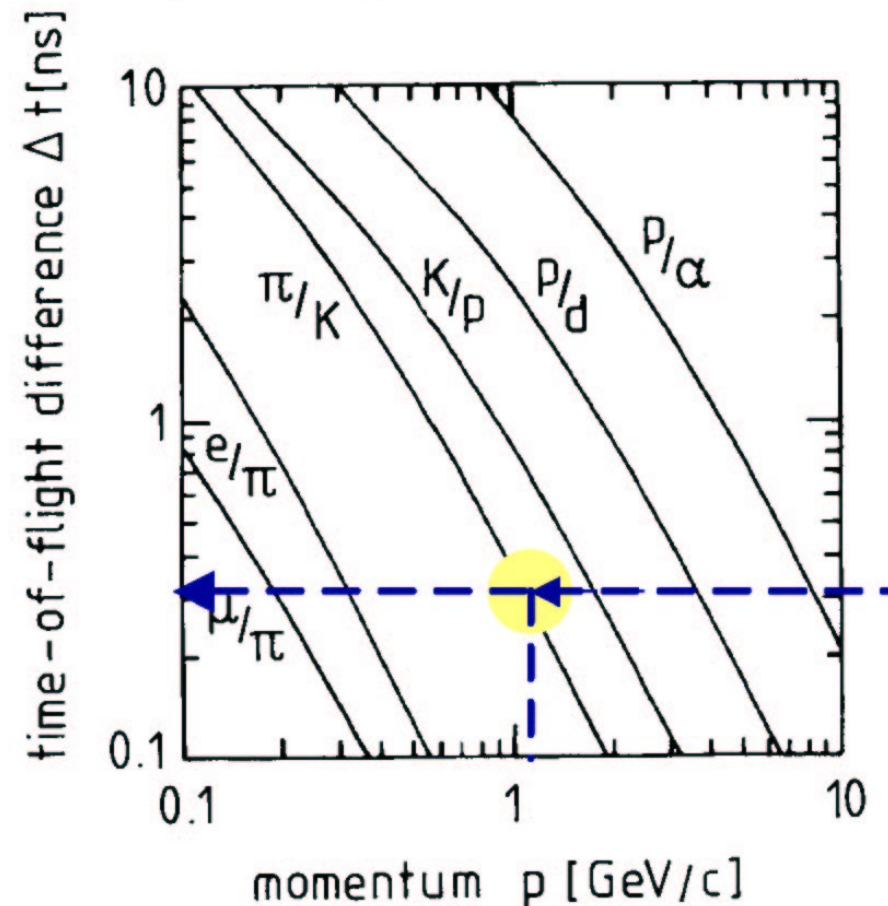

# Time-of-Flight (TOF) counters

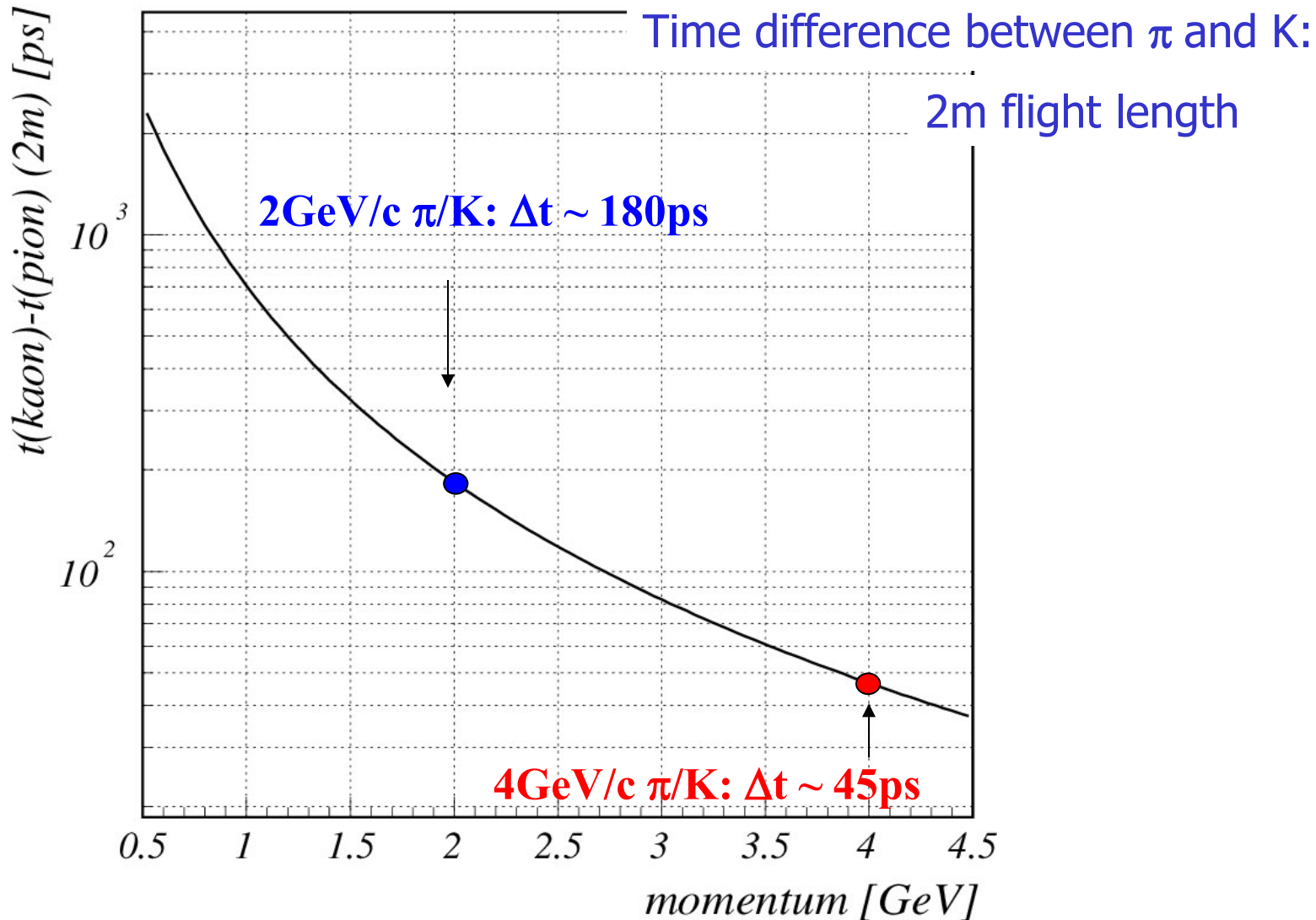

# Time-of-flight with fast photon detectors

## Expected p/K separation

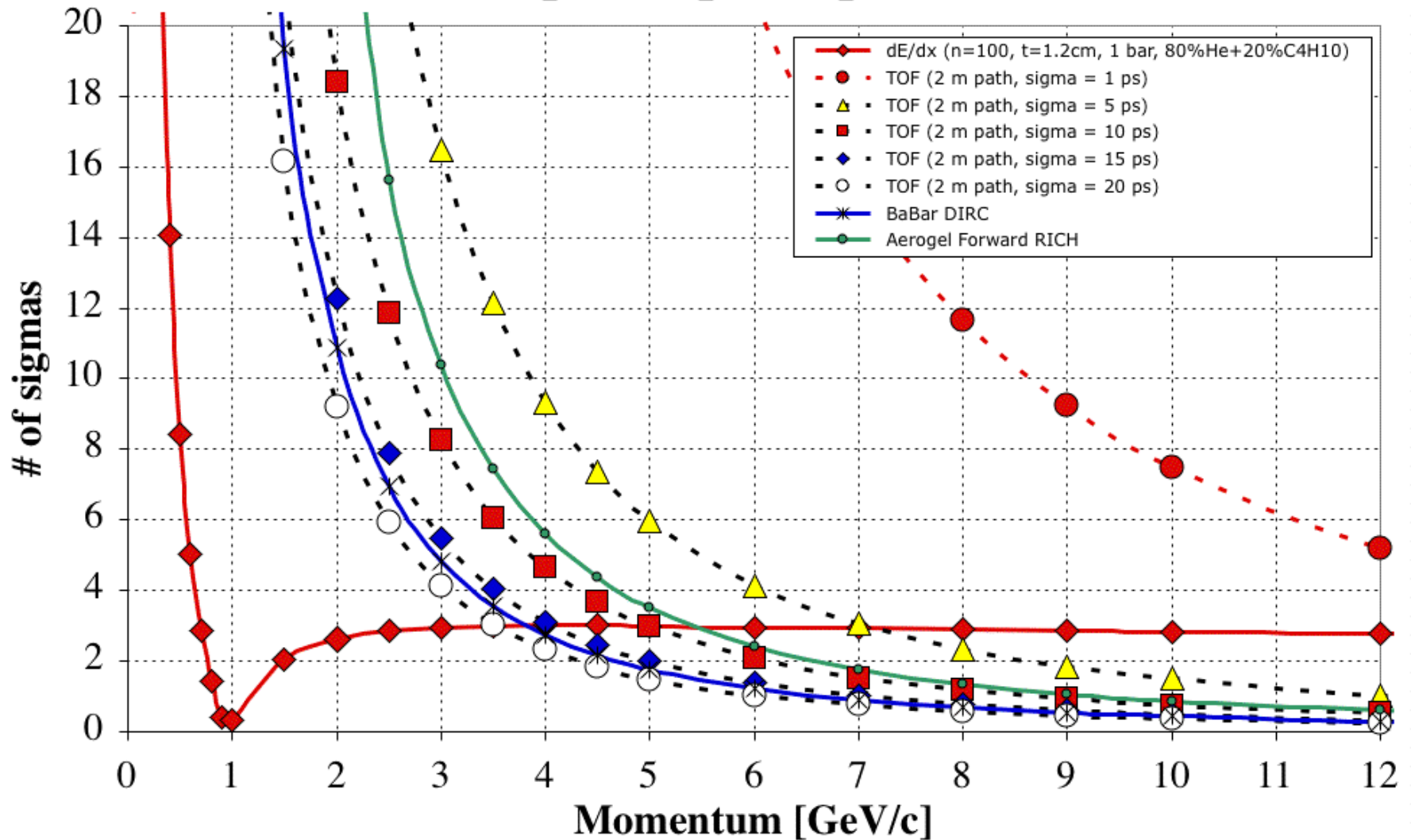

# Identification with the $dE/dx$ measurement

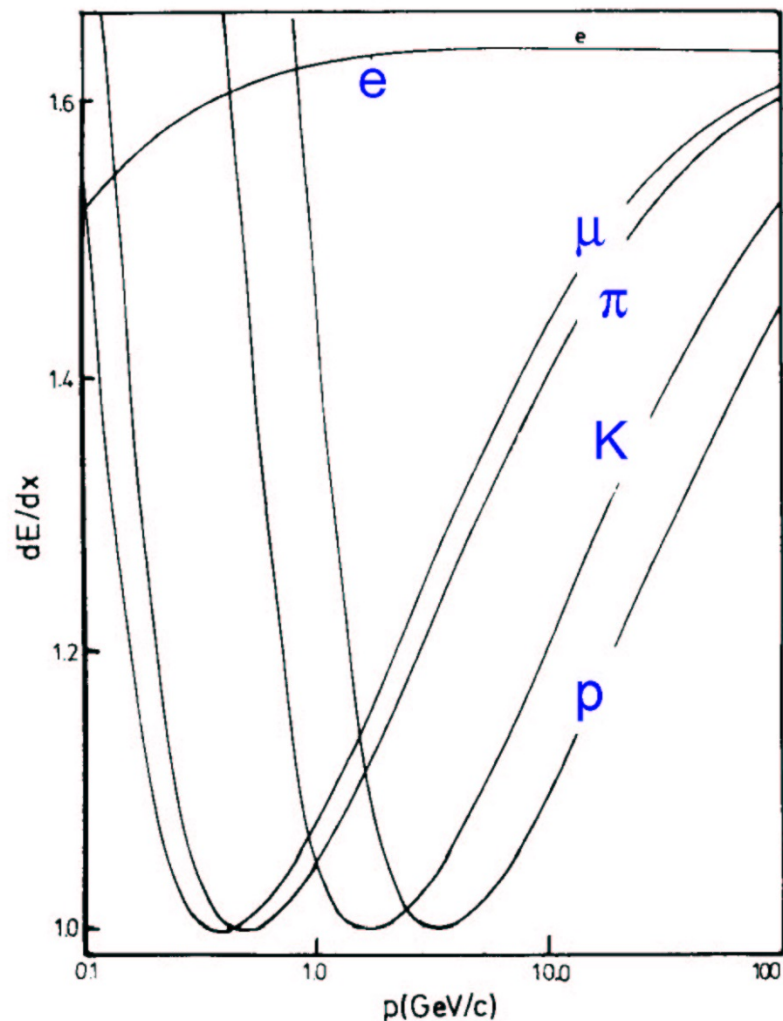
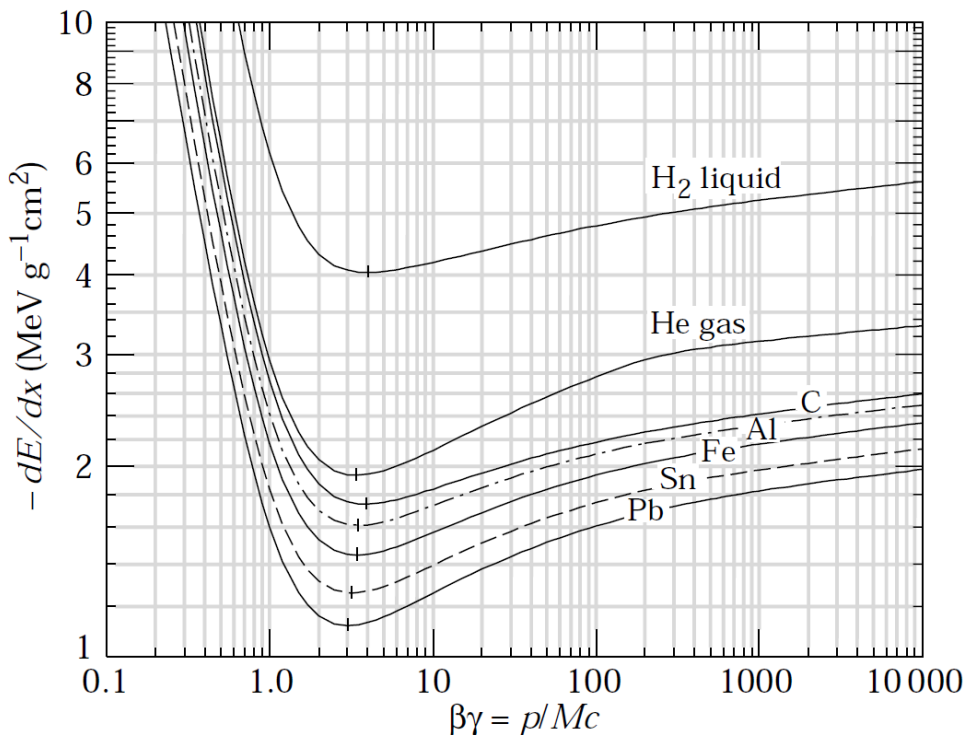

$dE/dx$  is a function of velocity  $\beta$

For particles with different mass the Bethe-Bloch curve gets displaced if plotted as a function of  $p$

For good separation: resolution should be  $\sim 5\%$

# Identification with dE/dx measurement 2

Problem: long tails (Landau distribution, not Gaussian)

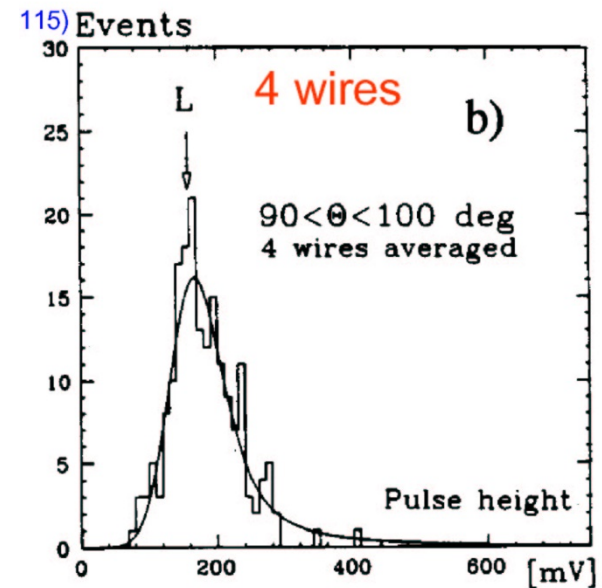
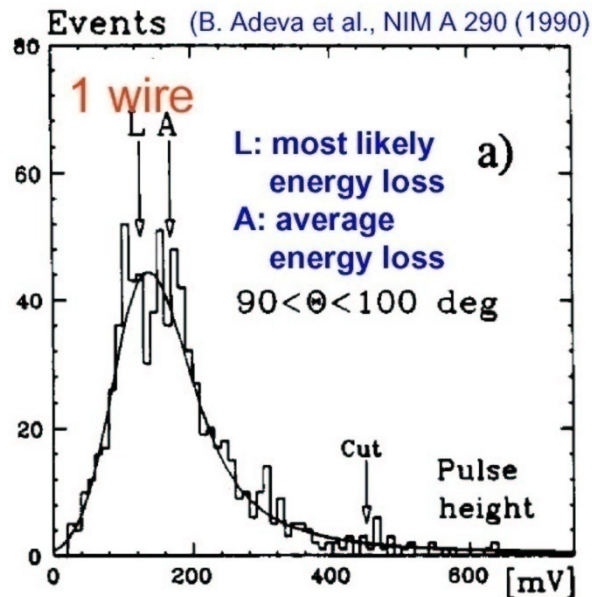

# Identification with dE/dx measurement

## dE/dx performance in the STAR TPC

gold-gold collisions

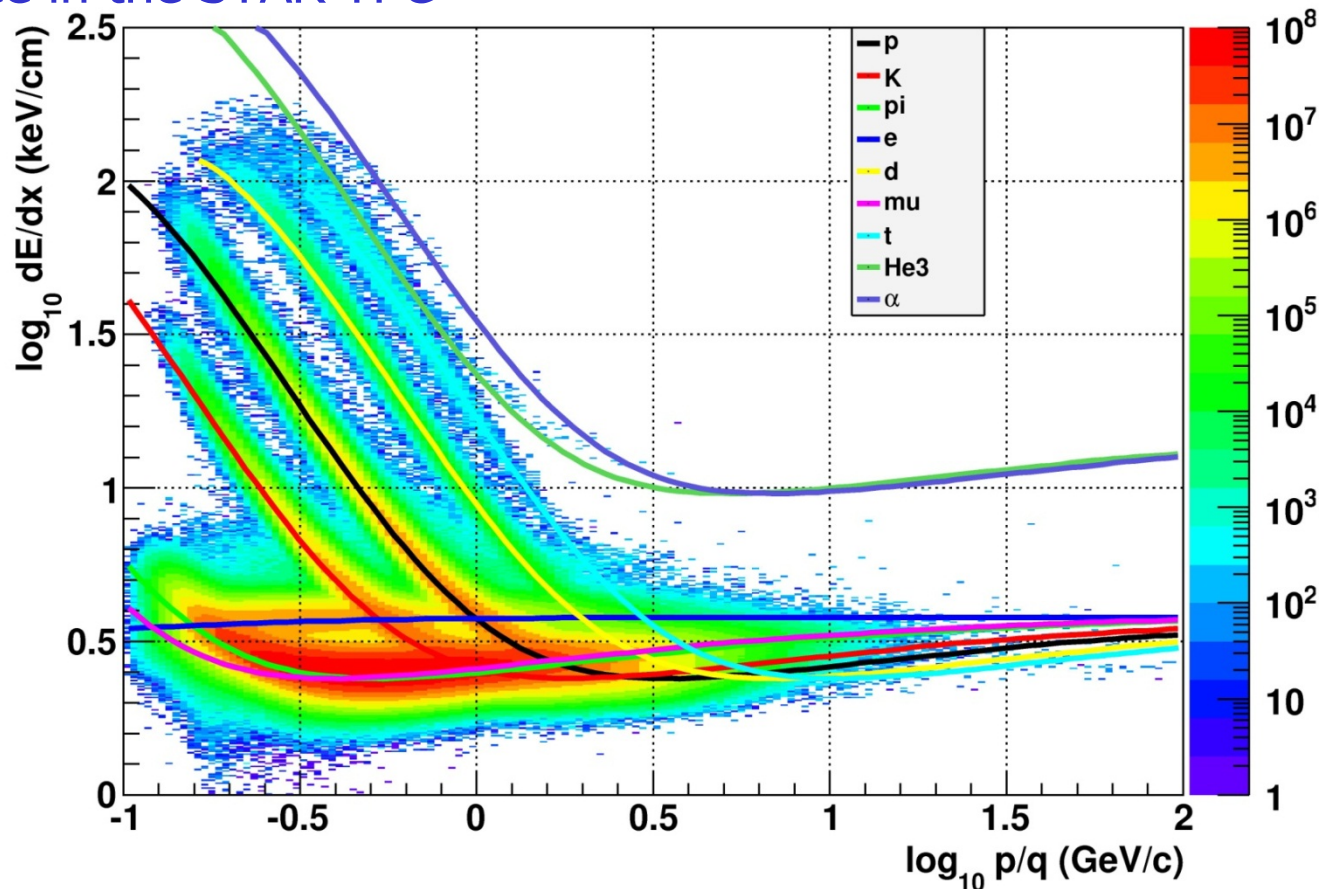

Energy loss in the STAR TPC: truncated mean as a function of momentum. The curves are Bichsel model predictions.

# Cherenkov radiation

A charged track with velocity  $v = \beta c$  exceeding the speed of light  $c/n$  in a medium with refractive index  $n$  emits **polarized light** at a characteristic (Cherenkov) angle,

$$\cos\theta = c_0/nv = 1/\beta n$$

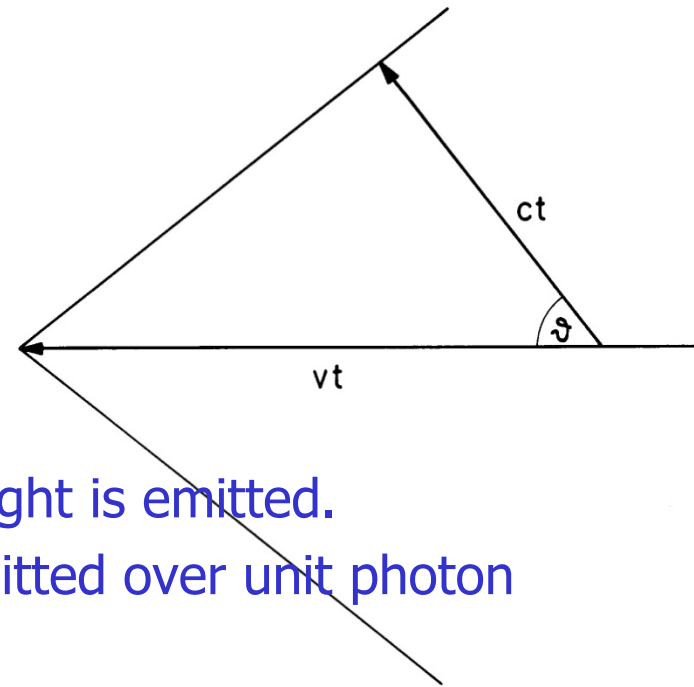

Two cases:

- $\beta < \beta_t = 1/n$ : below threshold **no** Cherenkov light is emitted.
- $\beta > \beta_t$ : the number of Cherenkov photons emitted over unit photon energy  $E = h\nu$  in a radiator of length  $L$ :

$$\frac{dN}{dE} = \frac{\alpha}{\hbar c} L \sin^2 \theta = 370(\text{cm})^{-1} (\text{eV})^{-1} L \sin^2 \theta$$

→ Few detected photons

# Measuring Cherenkov angle

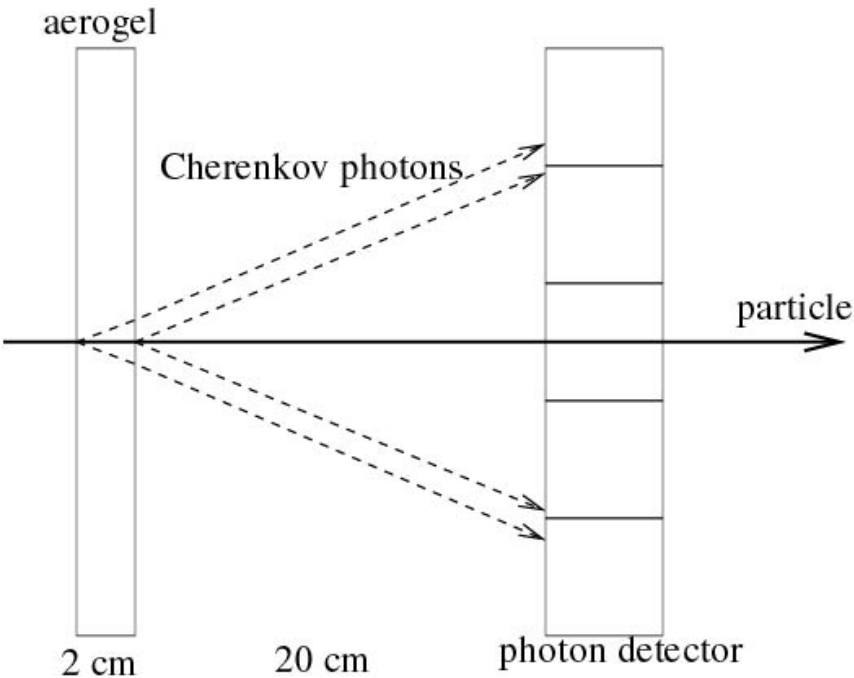

Proximity focusing RICH

RICH with a focusing mirror

Idea: transform the **direction** into a **coordinate** → ring on the detection plane → **Ring Imaging Cherenkov**

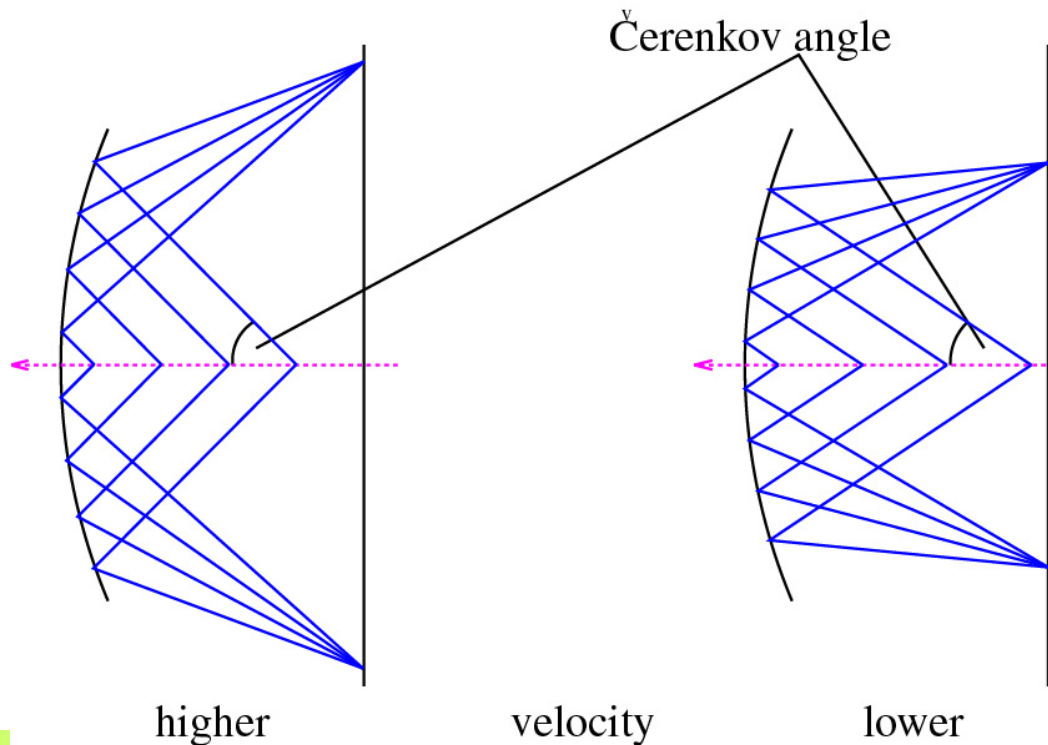

# Measuring Cherenkov angle

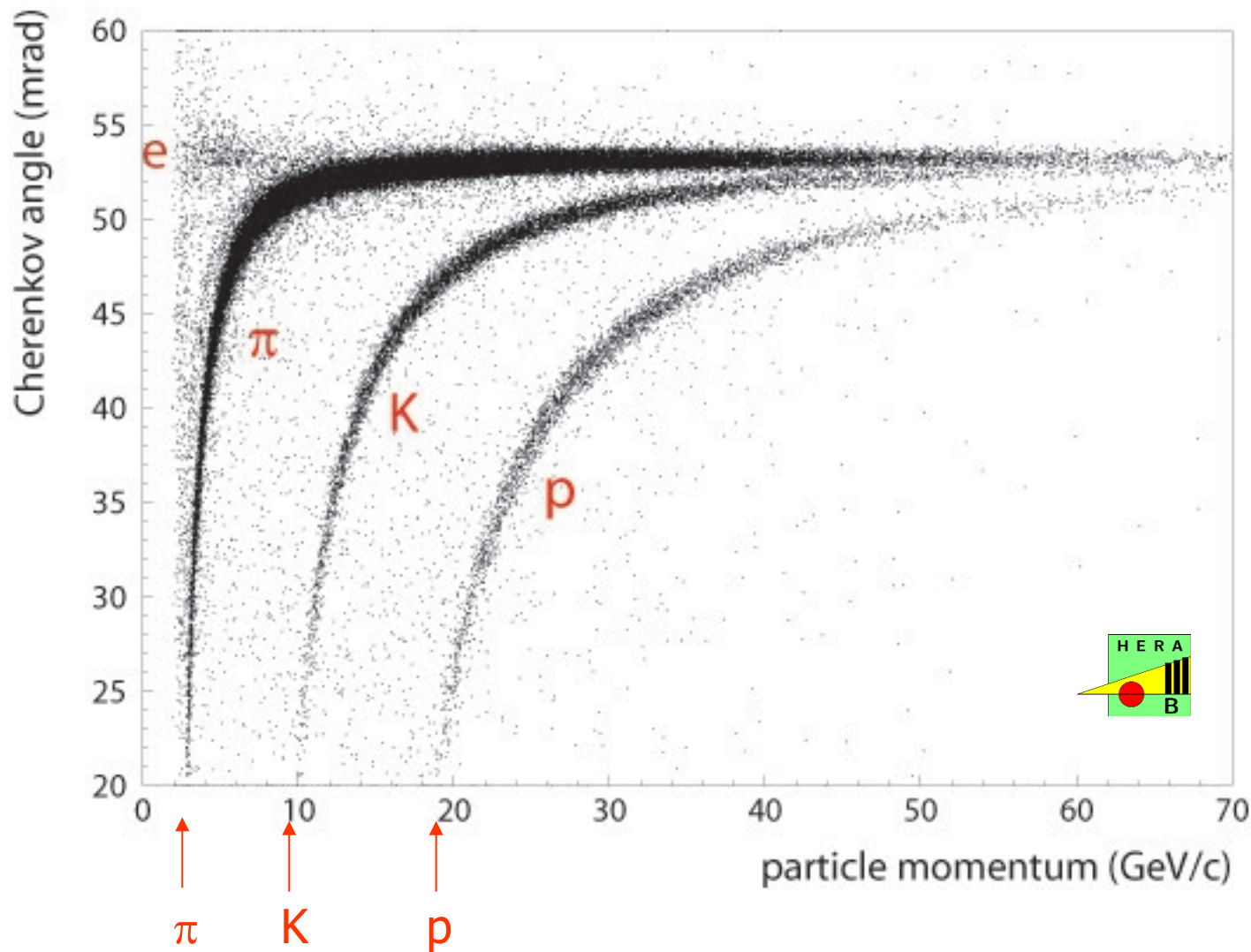

Radiator:  
 $C_4F_{10}$  gas

thresholds

# Photon detection in RICH counters

RICH counter: measure photon impact point on the photon detector surface

→ detection of **single** photons with

- sufficient **spatial resolution**
- **high efficiency** and **good signal-to-noise** ratio (few photons!)
- over a **large area** (square meters)

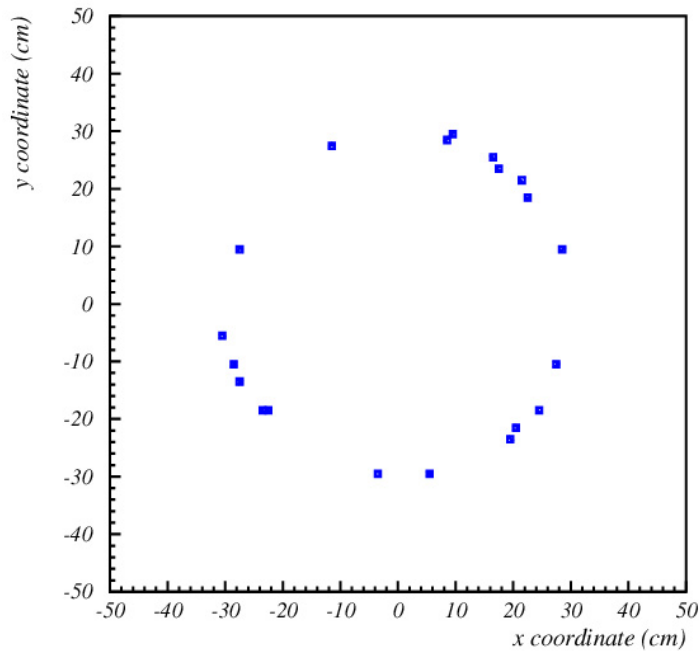

Special requirements:

- **Operation in magnetic field**
- **High rate capability**
- **Very high spatial resolution**
- **Excellent timing (time-of-arrival information)**

# Resolution of a RICH counter

Determined by:

- Photon impact point resolution ( $\sim$ photon detector granularity)
- Emission point uncertainty (not in a focusing RICH)
- Dispersion:  $1/\beta = n(\lambda) \cos\theta$
- Errors of the optical system
- Uncertainty in track parameters

Resolution per track:

$$\sigma_{track} = \frac{\sigma_0}{\sqrt{N_{pe}}}$$

single photon resolution  $\rightarrow \sigma_0$

$\rightarrow N_{pe}$  # of detected photons

(in the case of low background)

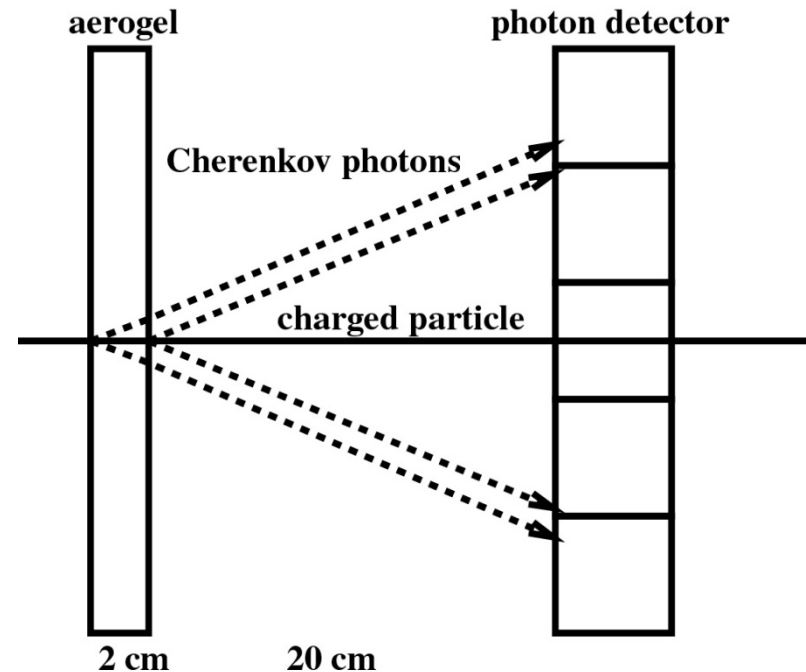

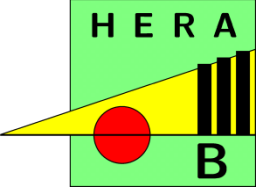

# HERA-B RICH

Photon  
Detectors

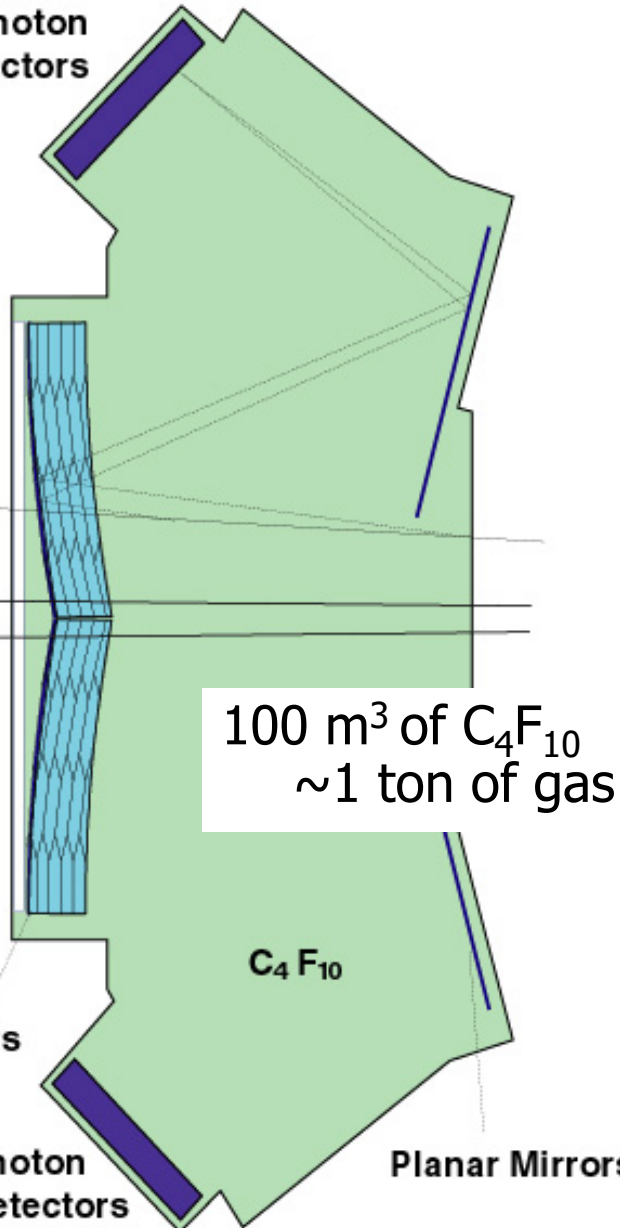

Photon detector requirements:

- High QE over  $\sim 3\text{m}^2$
- Rates  $\sim 1\text{MHz}$
- Long term stability

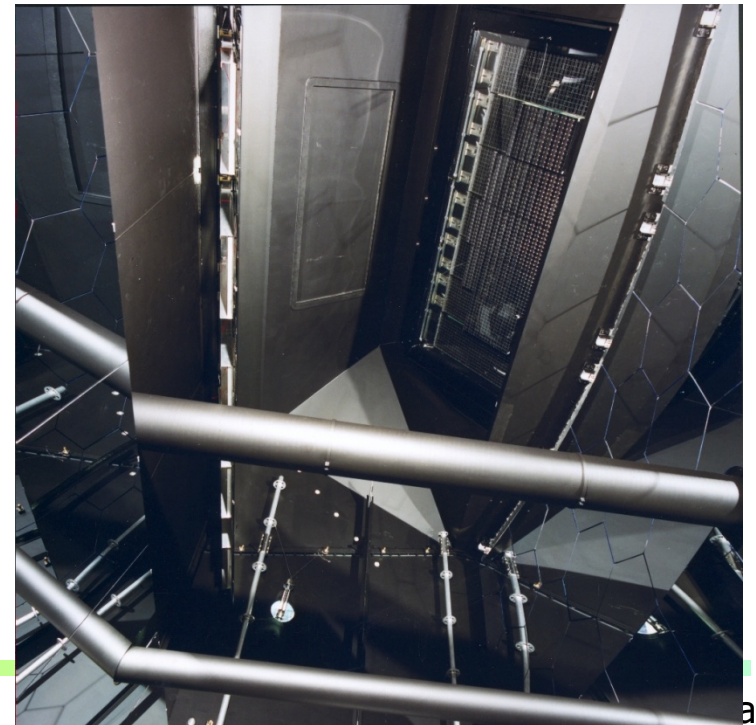

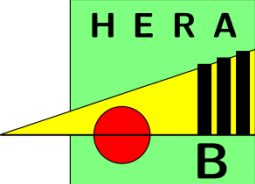

# Multianode PMTs

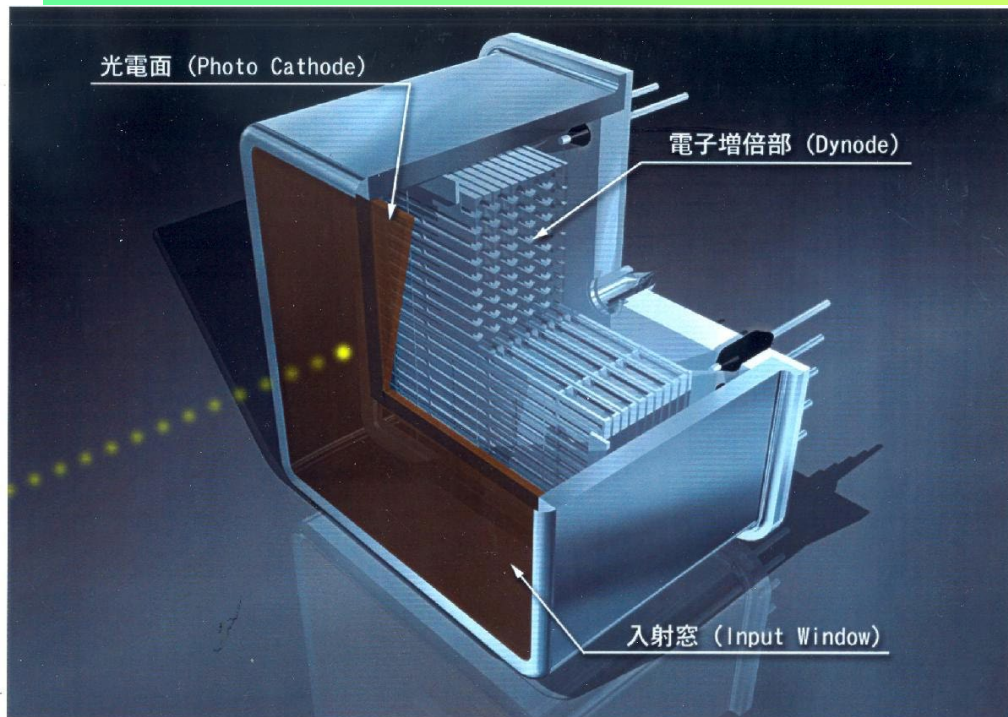

Multianode PMTs with metal foil dynodes and 2x2, 4x4 or 8x8 anodes Hamamatsu R5900 (and follow up types 7600, 8500)

→ Excellent single photon pulse height spectrum

→ Low noise (few Hz/ch)

→ Low cross-talk (<1%)

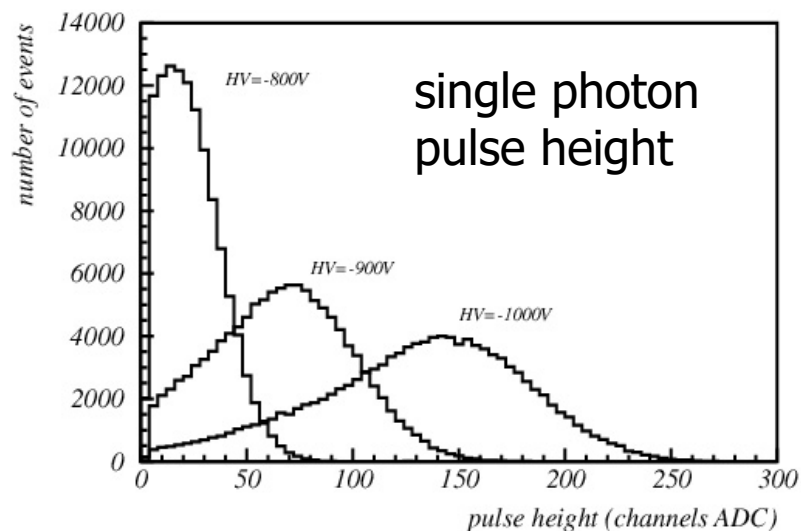

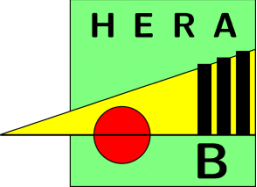

# HERA-B RICH photon detector

Light collection system  
(imaging!) to:

- Eliminate dead areas
- Adapt the pad size

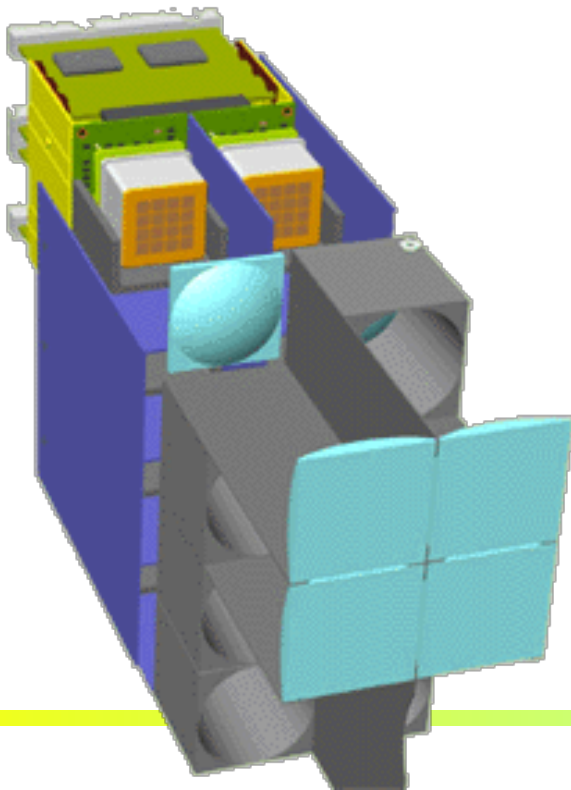

Field lens, 35 mm x 35 mm

Condenser lens  
diameter 32 mm

PMT active area  
18 mm x 18 mm

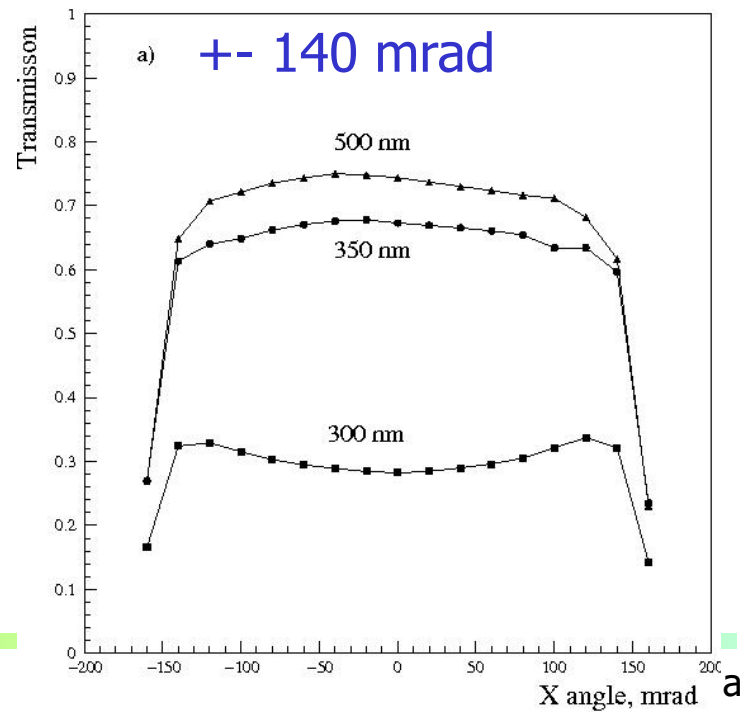
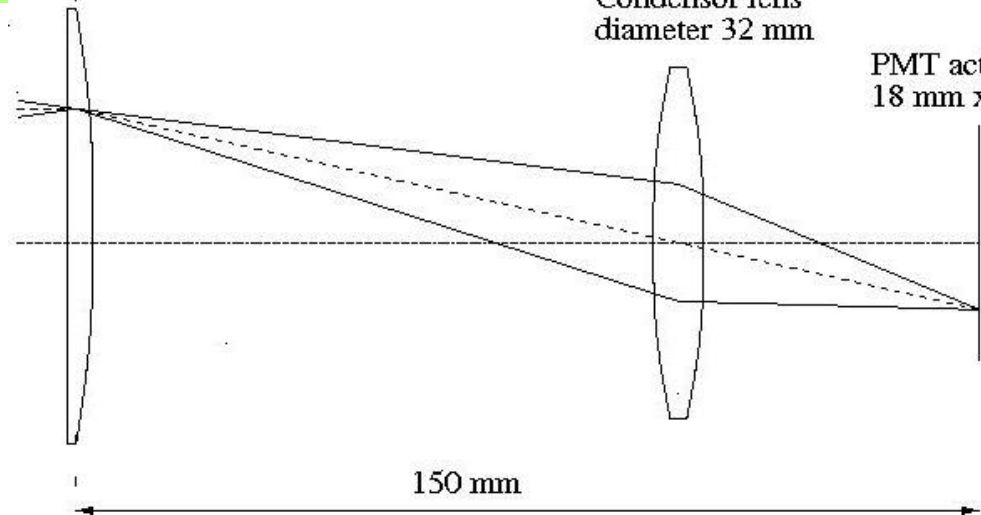

# HERA-B RICH

← Little noise, ~30 photons per ring

Typical event →

Worked very well!

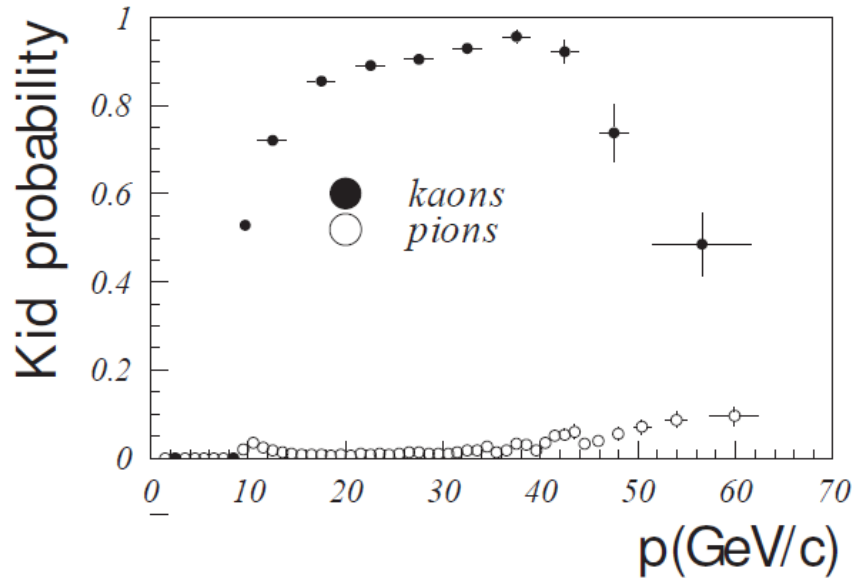
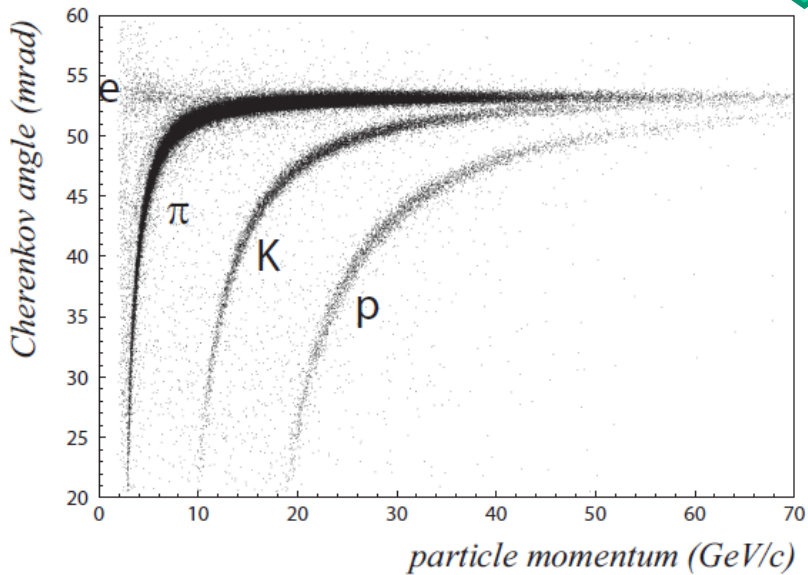

Kaon efficiency and pion fake probability

# Limits of the RICH technique

---

The choice of RICH radiator medium in case of a specific experiment depends on the particles we would like to identify, and their kinematics:

- the threshold momentum for the lighter of the two particles we want to separate:  $\mathbf{p}_t = \beta_t \gamma_t \mathbf{m} \mathbf{c}$ ,  $\beta_t = \mathbf{1}/\mathbf{n}$  should coincide with the lower limit of momentum spectrum  $p_{\min}$ . Typically

$$\mathbf{p}_{\min} = \text{sqrt } 2 \mathbf{p}_t$$

- the resolution in Čerenkov angle should allow for a separation up to the upper limits of kinematically allowed momenta  $\mathbf{p}_{\max}$

# Limits of a RICH detector

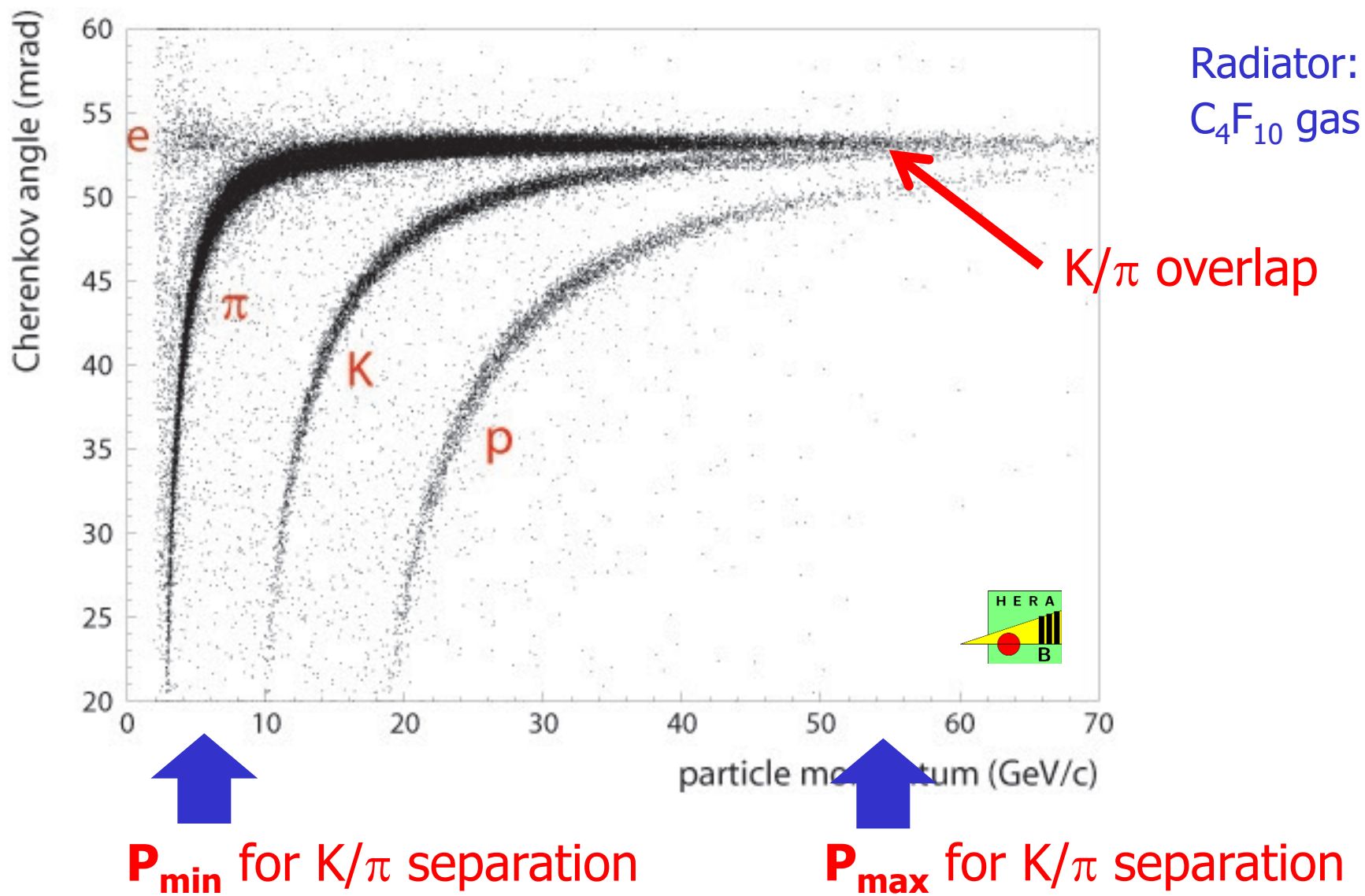

## $\pi/K$ separation example:

Limiting performance at the high momentum side: irreducible contribution to the resolution - dispersion.

radiator	LiF solid	C <sub>6</sub> F <sub>14</sub> liquid	C <sub>5</sub> F <sub>12</sub> gas	N <sub>2</sub> gas	He gas
$\sigma_\theta$ (mrad)	7.0	3.9	0.45	0.40	0.13
$\sigma_N$ (mrad)	2.2	1.2	0.14	0.13	0.04
$p_{max}$ (GeV/c) for $3\sigma \pi/K$	3.5	6.9	50	100	330
$p_{min}$ (GeV/c)	0.6	0.9	11	28	83

photon detector: TMAE, 10 det. photons assumed

Summary:

$$p_{max} / p_{min} \sim 4-7$$

for a  $3\sigma$  separation between the two particles

For a larger kinematic region **2 radiators are needed!**

# The LHCb RICH counters

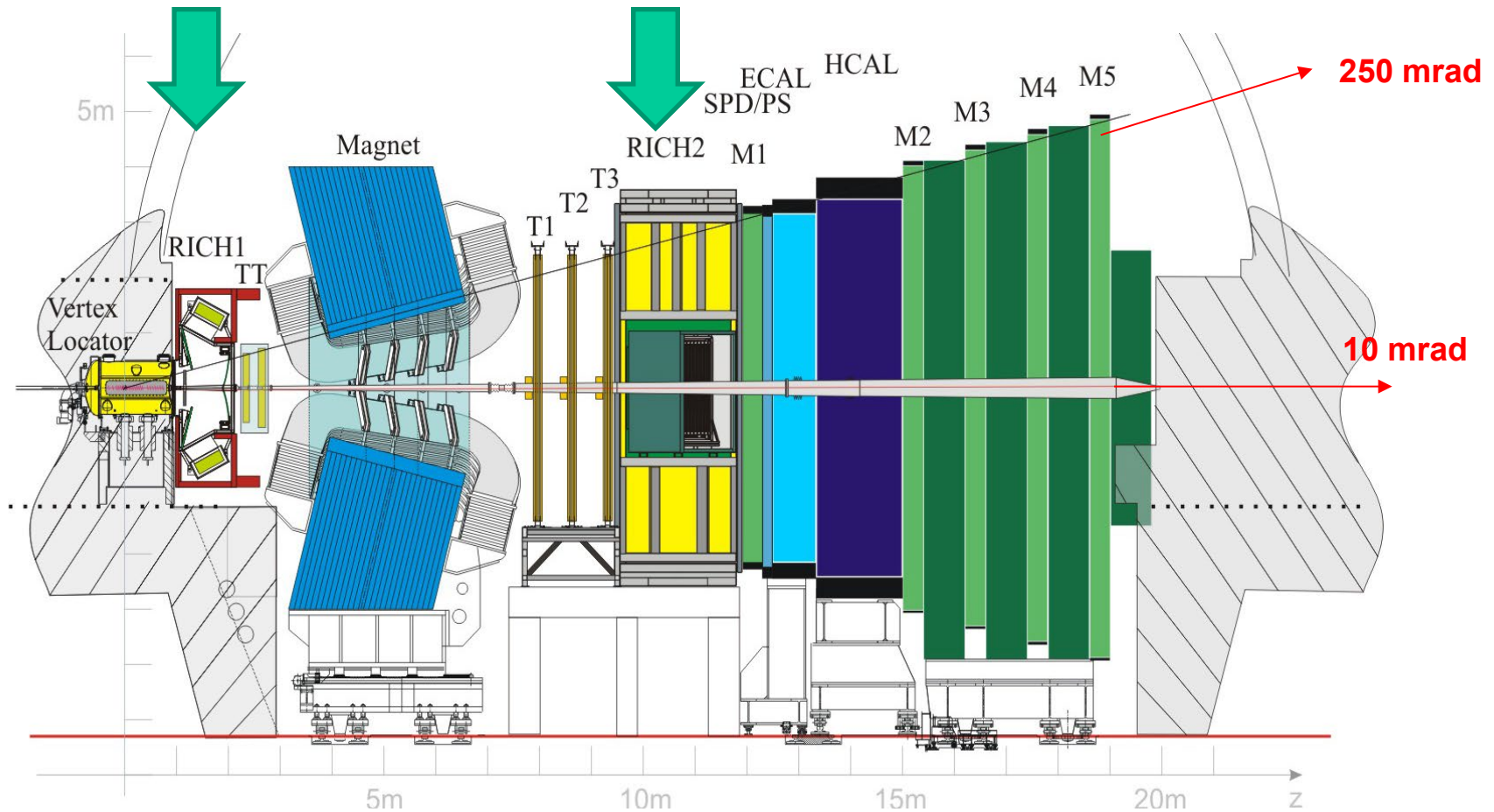

**Vertex reconstruction:**  
**VELO**

**Trigger:**  
**Muon Chambers**  
**Calorimeters**  
**Tracker**

**PID:**  
**RICHes**  
**Calorimeters**  
**Muon Chambers**

**Kinematics:**  
**Magnet**  
**Tracker**  
**Calorimeters**

# LHCb RICHes

Need:

- Particle identification for momentum range  $\sim 2\text{-}100\text{ GeV}/c$
- Granularity  $2.5 \times 2.5\text{ mm}^2$
- Large area ( $2.8\text{ m}^2$ ) with high active area fraction
- Fast compared to the 25ns bunch crossing time
- Have to operate in a small B field

→ 3 radiators

- Aerogel
- $\text{C}_4\text{F}_{10}$
- $\text{CF}_4$

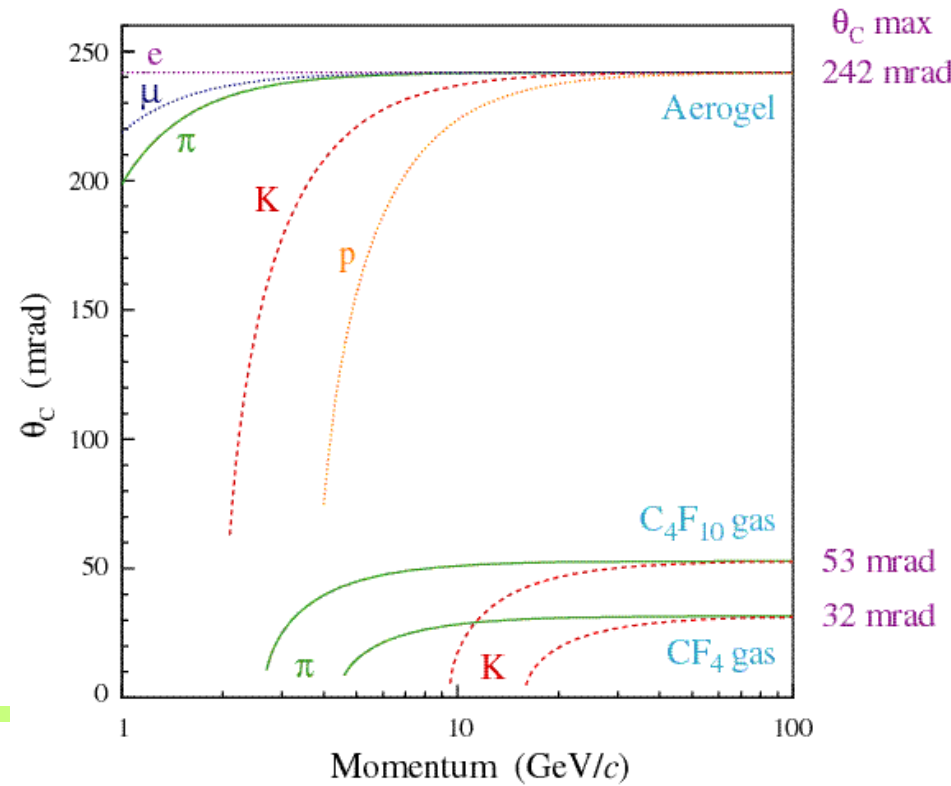

# LHCb RICHes: performance

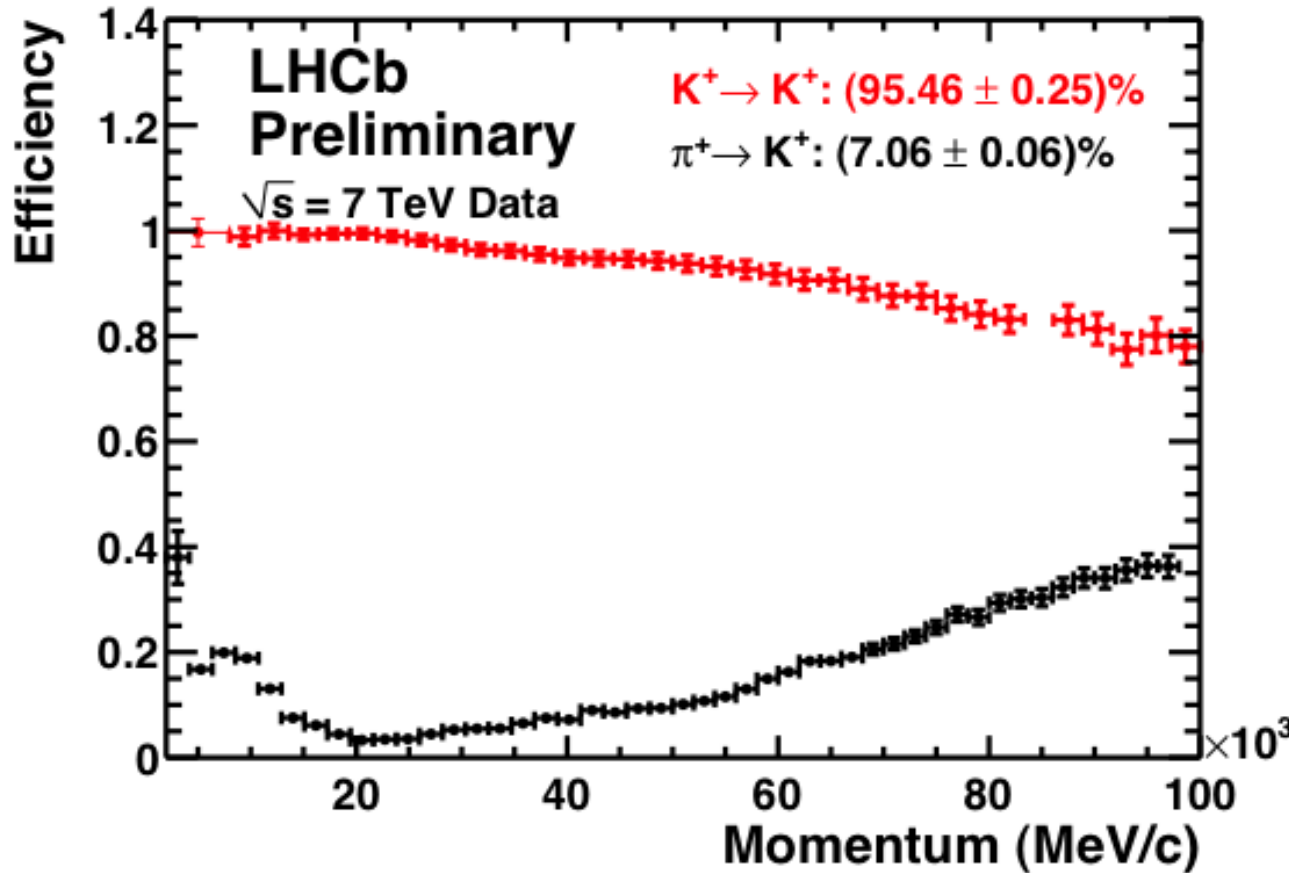

Efficiency and purity from data  $\rightarrow$   
 excellent agreement with MC

N. Harnew, Beauty 2011

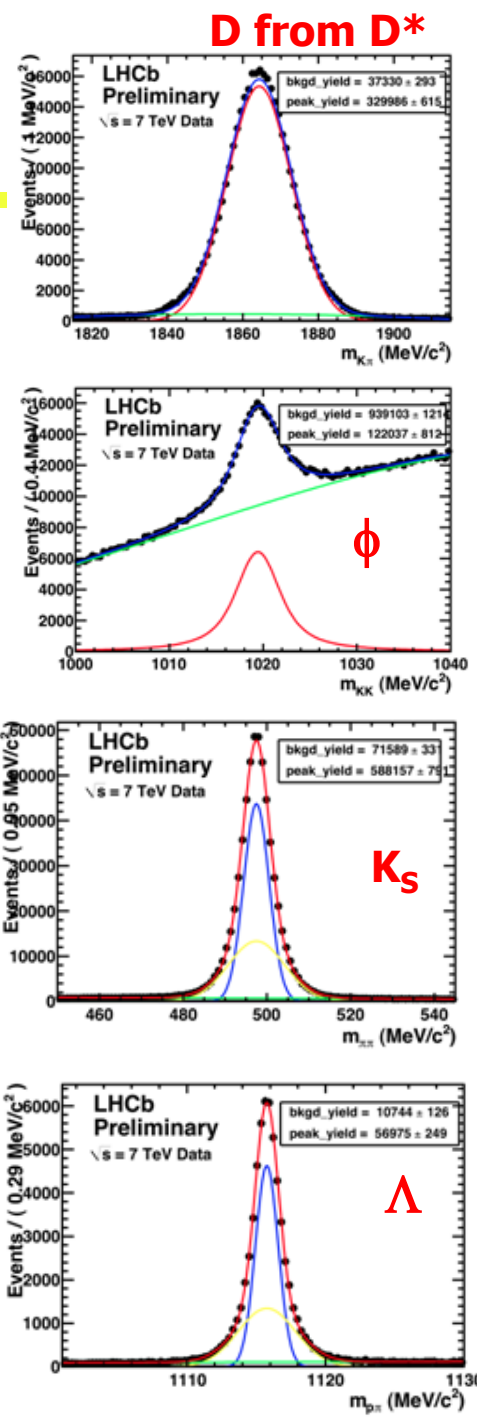

# Belle II PID systems – side view

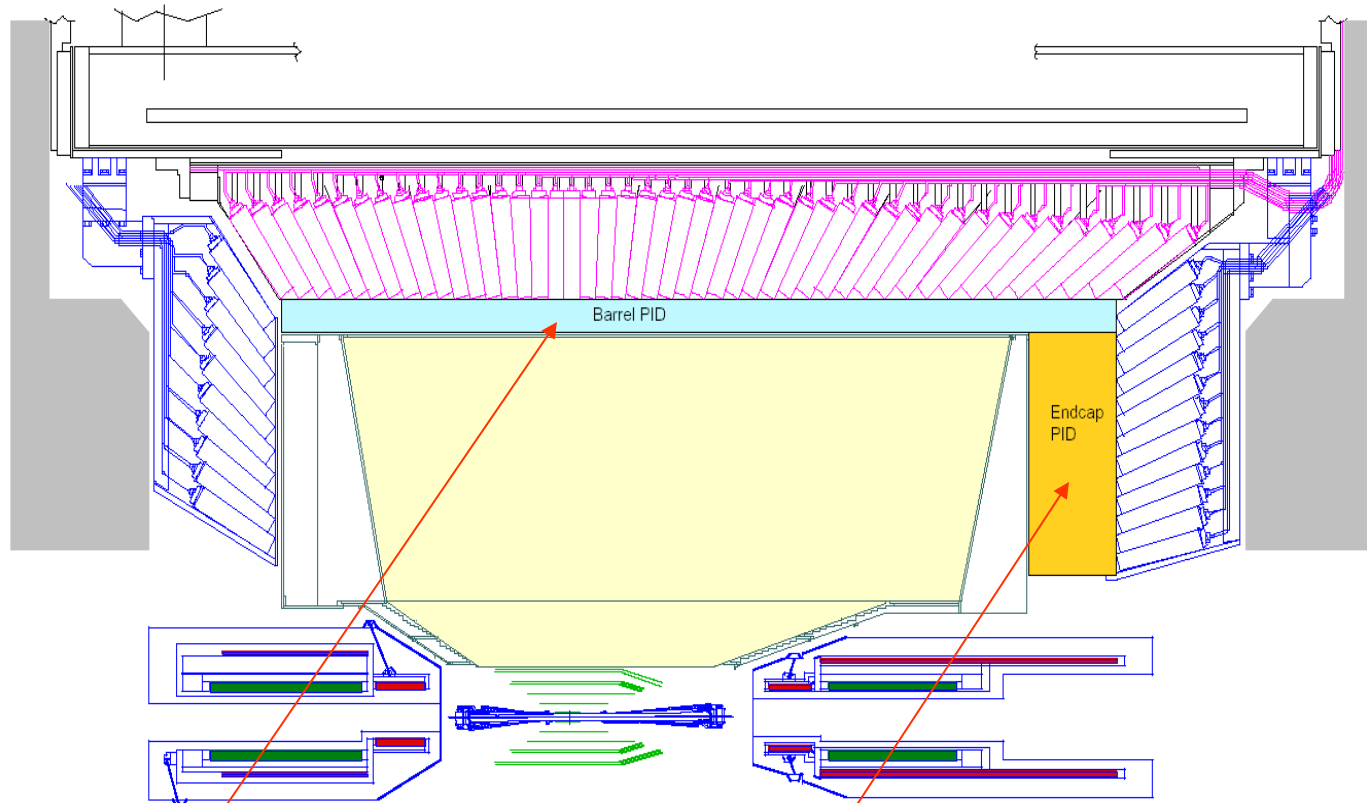

Two new particle ID devices, both RICHes:

Barrel: **time-of-propagation (TOP) counter**

Endcap: **proximity focusing RICH**



# Time-Of-Propagation (TOP) counter

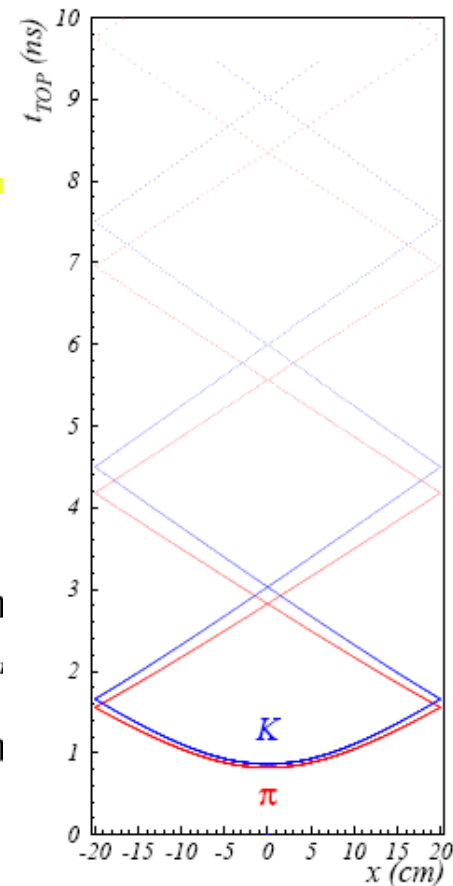
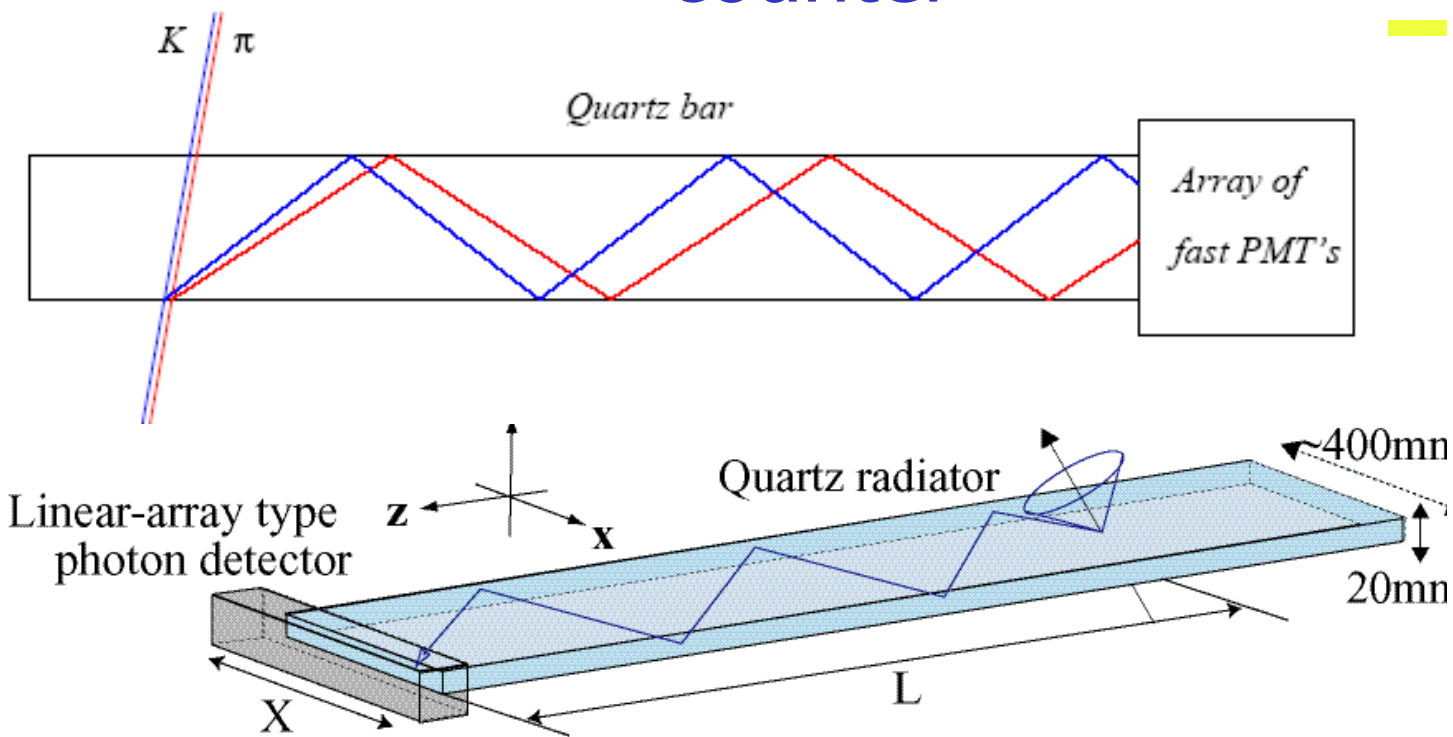

Similar to DIRC, but instead of two coordinates measure:

- One (or two coordinates) with a few mm precision
- Time-of-arrival
- Excellent time resolution  $< \sim 40\text{ps}$  required for single photons in 1.5T B field

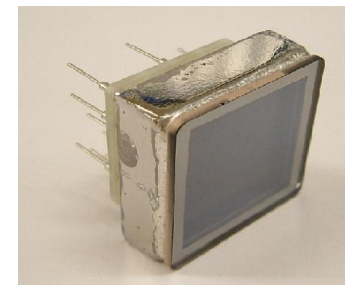

Hamamatsu SL10 MCP-PMT



# Belle II PID system

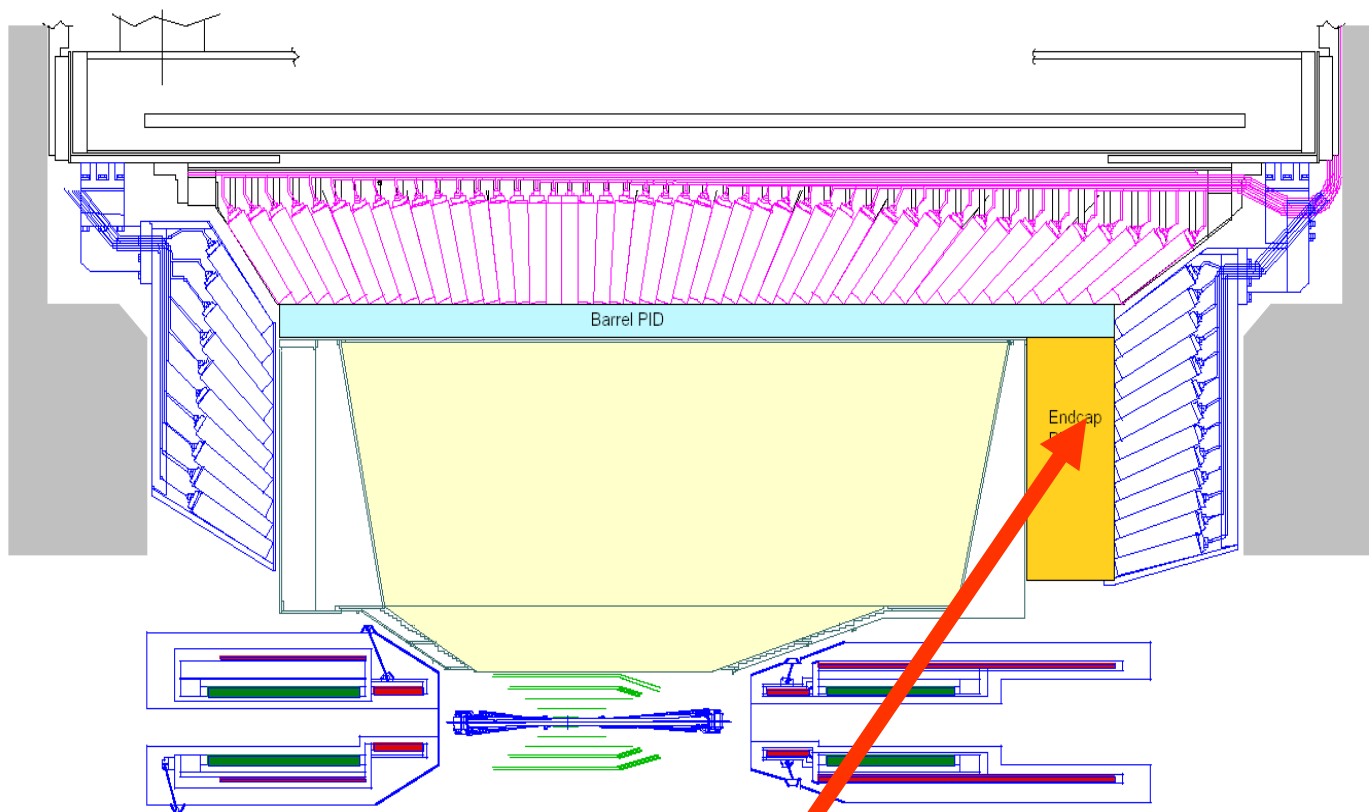

Two new particle ID devices, both RICHes:

Barrel: Time-of-propagation counter (TOP) counter

Endcap: proximity focusing RICH

# Endcap: Proximity focusing RICH

K/ $\pi$  separation at 4 GeV/c:  
 $\theta_c(\pi) \sim 308$  mrad ( $n = 1.05$ )  
 $\theta_c(\pi) - \theta_c(K) \sim 23$  mrad

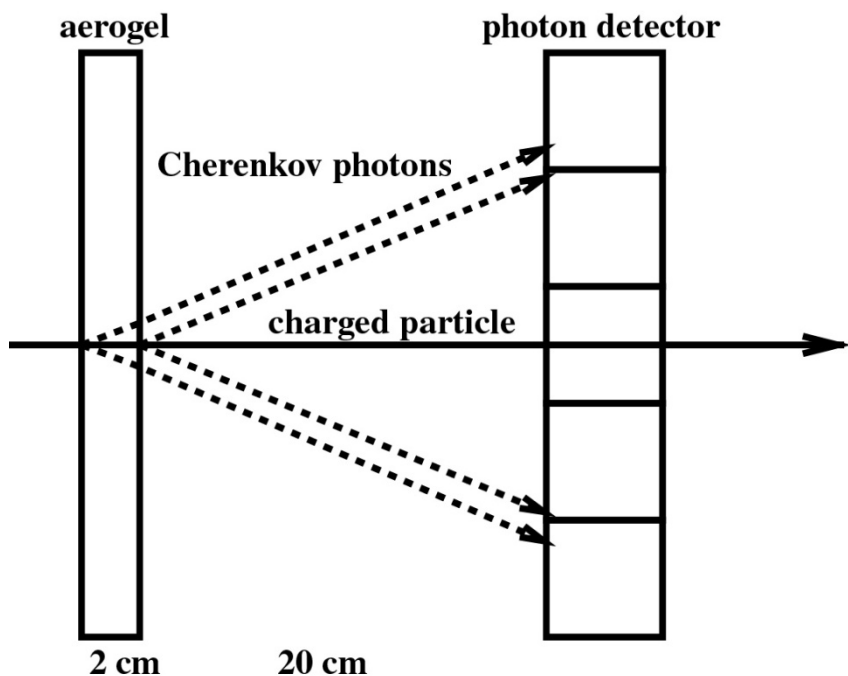

For single photons:  $\delta\theta_c(\text{meas.}) = \sigma_0 \sim 14$  mrad,  
 typical value for a 20mm thick radiator and  
 6mm PMT pad size

Per track:

$$\sigma_{\text{track}} = \frac{\sigma_0}{\sqrt{N_{pe}}}$$

Separation:  $[\theta_c(\pi) - \theta_c(K)] / \sigma_{\text{track}}$

$\rightarrow 5\sigma$  separation with  $N_{pe} \sim 10$

# Radiator with multiple refractive indices

How to increase the number of photons without degrading the resolution?

normal

→ stack two tiles with different refractive indices:  
“focusing” configuration

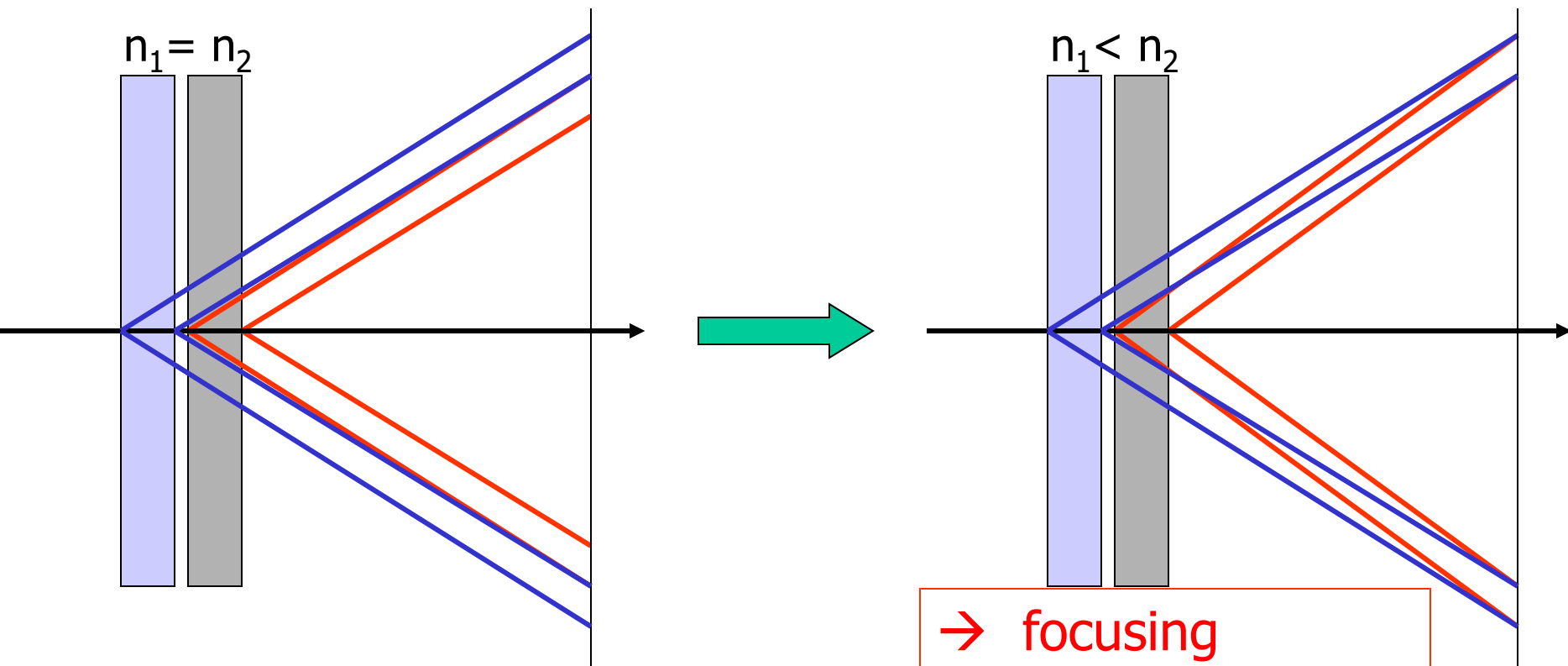

Such a configuration is only possible with aerogel (a form of  $\text{Si}_x\text{O}_y$ )  
– material with a tunable refractive index between 1.01 and 1.13.

# Focusing configuration – data

## 4cm aerogel single index

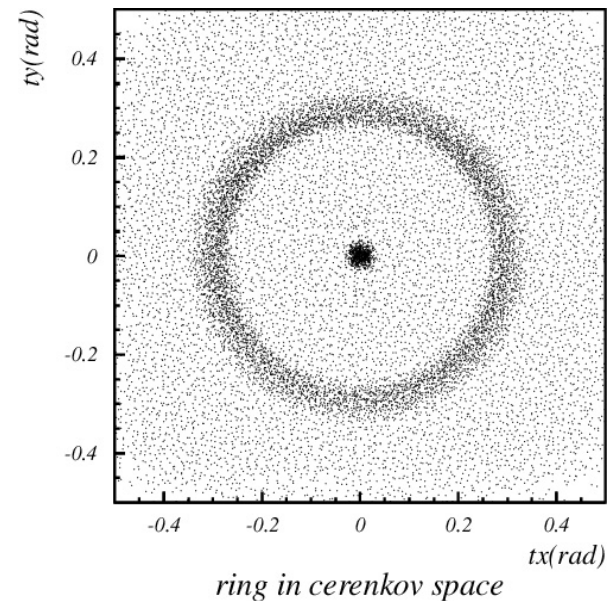
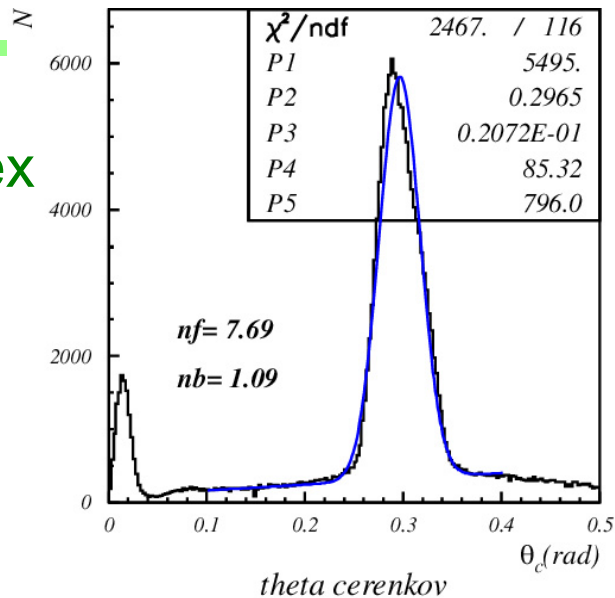
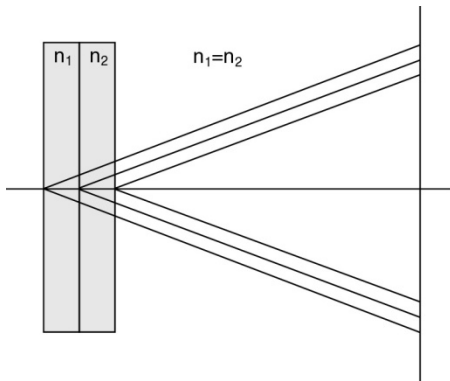

## 2+2cm aerogel

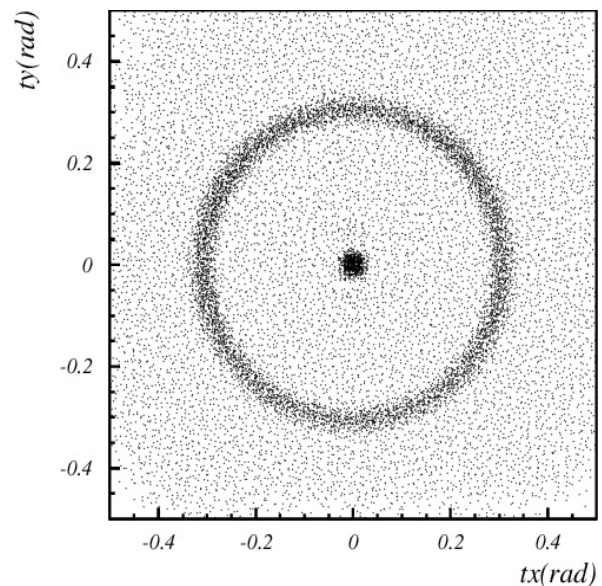
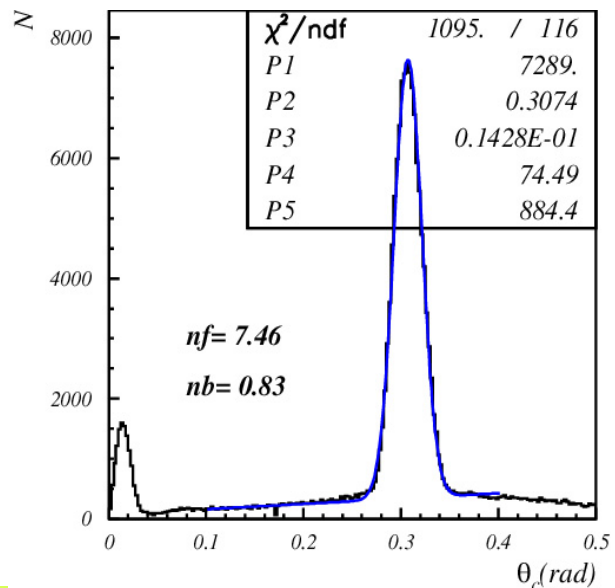
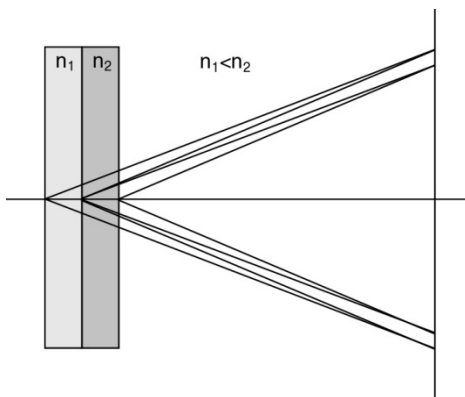

# Aerogel RICH photon detectors

Need:

Operation in 1.5 T magnetic field

Pad size  $\sim 5\text{-}6\text{mm}$

Baseline option: large active area HAPD  
of the proximity focusing type

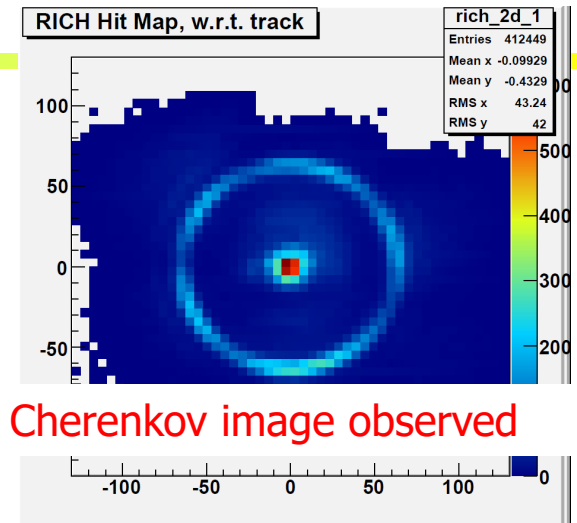
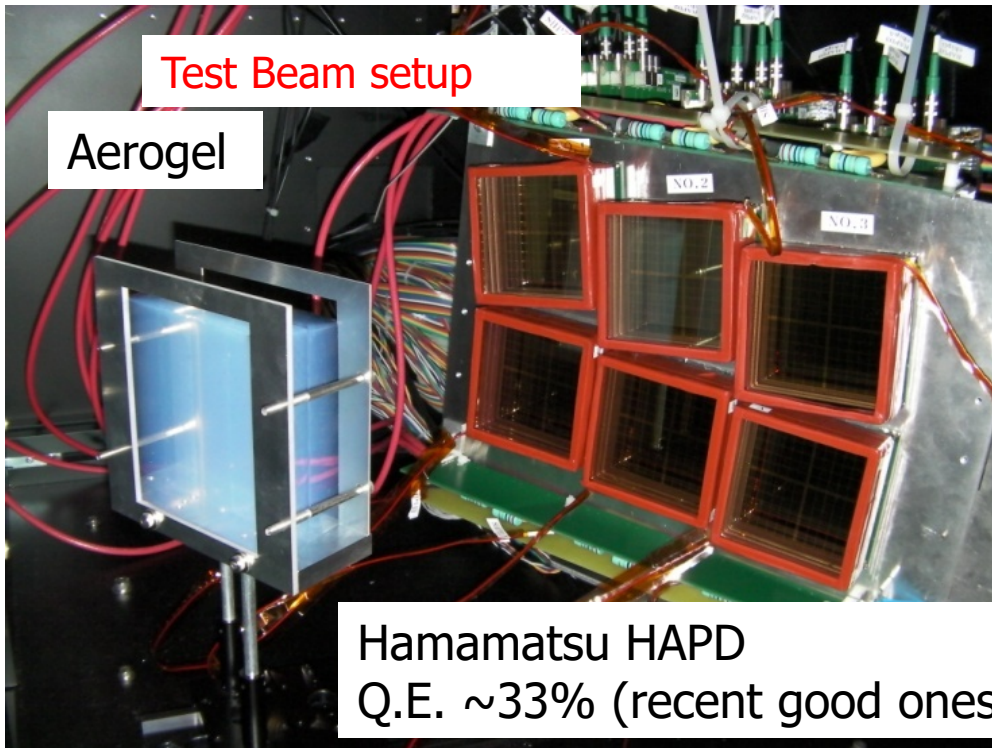

Cherenkov angle distribution

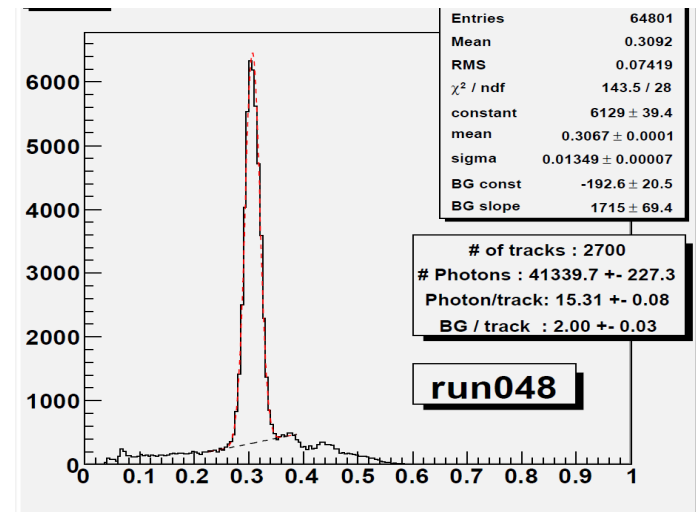

**$6.6 \sigma$  p/K at  $4\text{GeV}/c$ !**

$\rightarrow$  NIM A595 (2008) 180

# Muon and $K_L$ detector at B factories

---

**Separate muons from hadrons (pions and kaons):** exploit the fact that muons interact only electromag., while hadrons interact strongly → need a few interaction lengths to stop hadrons (interaction lengths = about 10x radiation length in iron, 20x in CsI). A particle is identified as muon if it penetrates the material.



# Example: Muon and $K_L$ detection at Belle

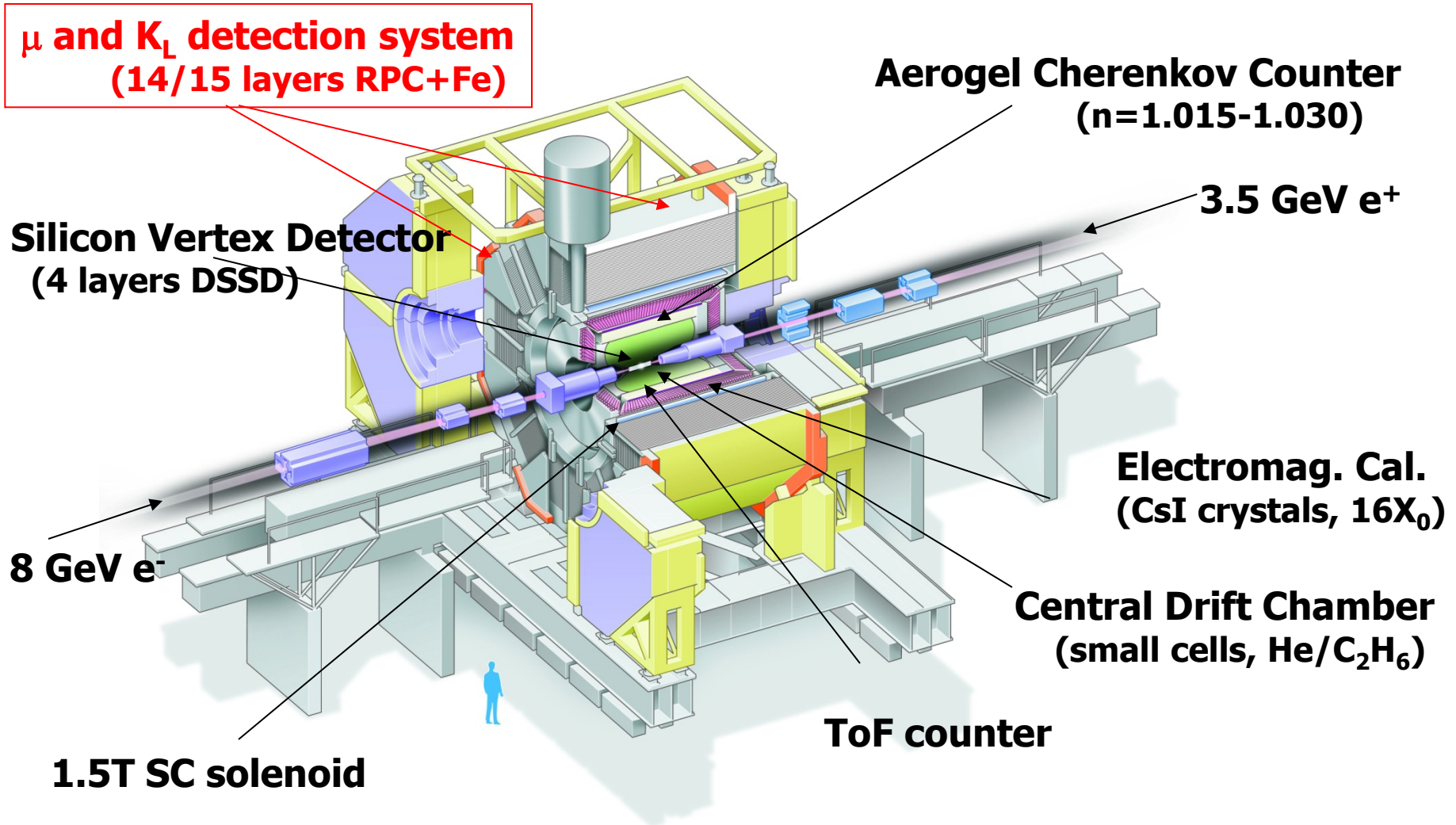

# Muon and $K_L$ detector

---

Up to 21 layers of resistive-plate chambers (RPCs) between iron plates of flux return

Bakelite RPCs at BABAR

Glass RPCs at Belle  
(better choice)

---

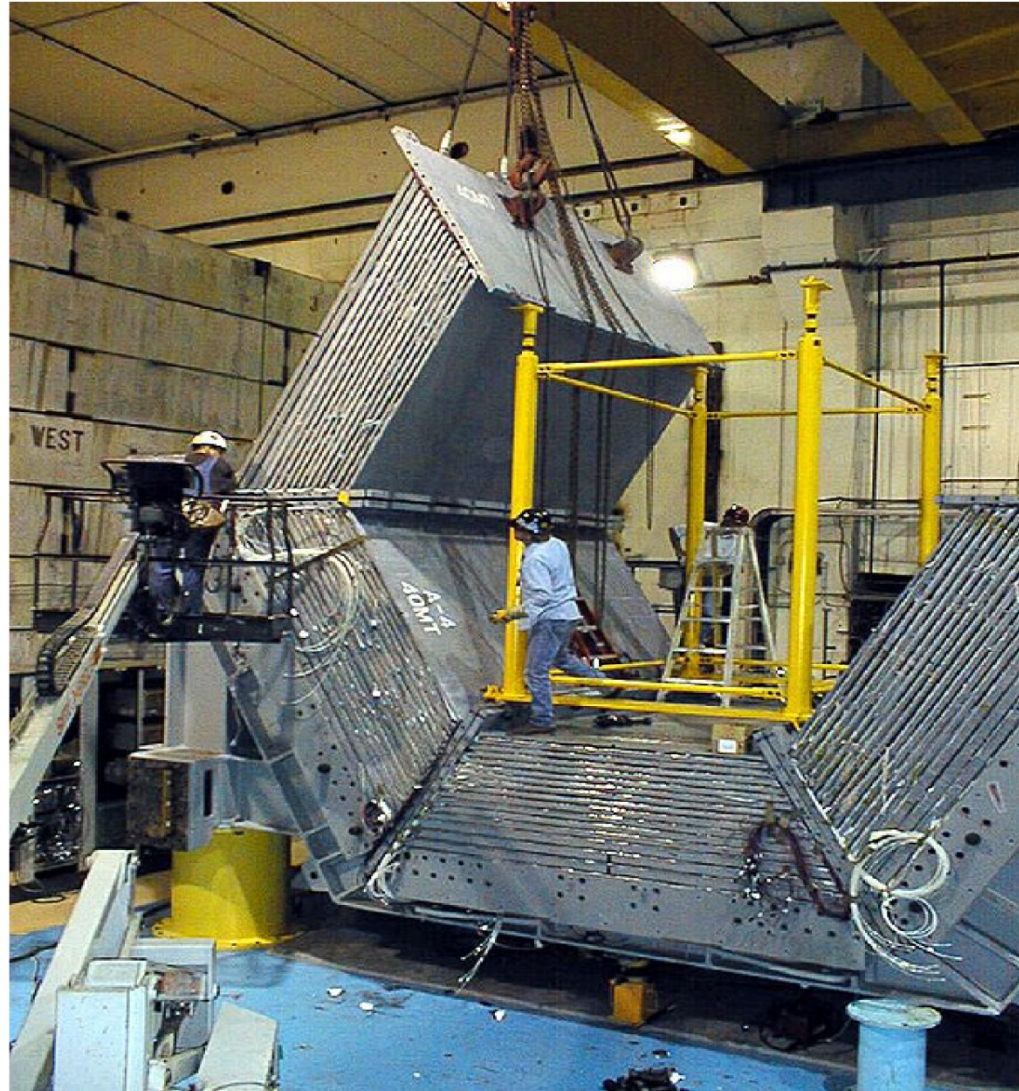

# Muon and $K_L$ detector

Example:

event with

- two muons and a

- $K_L$

and a pion that  
partly penetrated

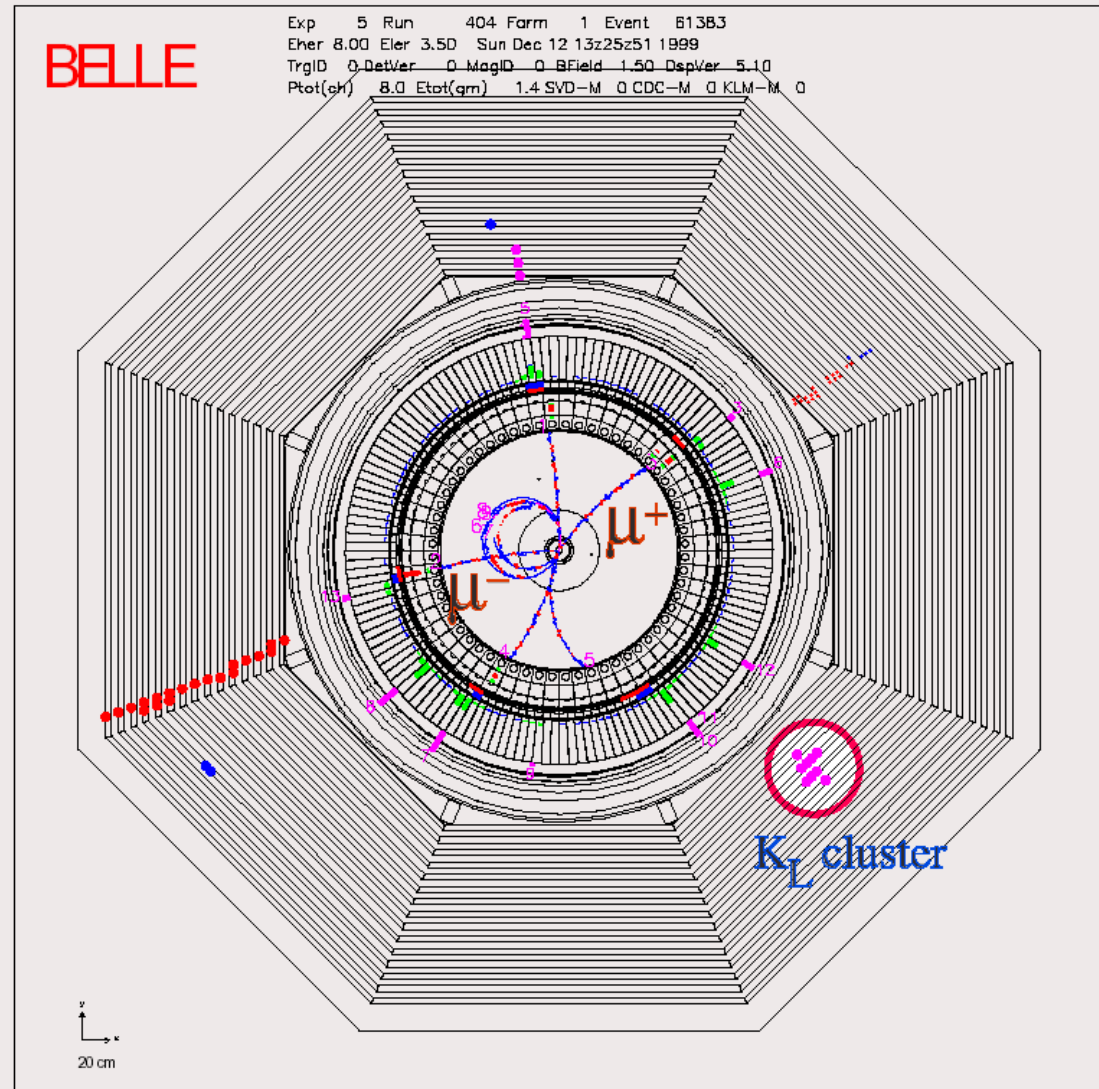

# Muon and $K_L$ detector performance

Muon identification: efficient for  $p > 800$  MeV/c

efficiency

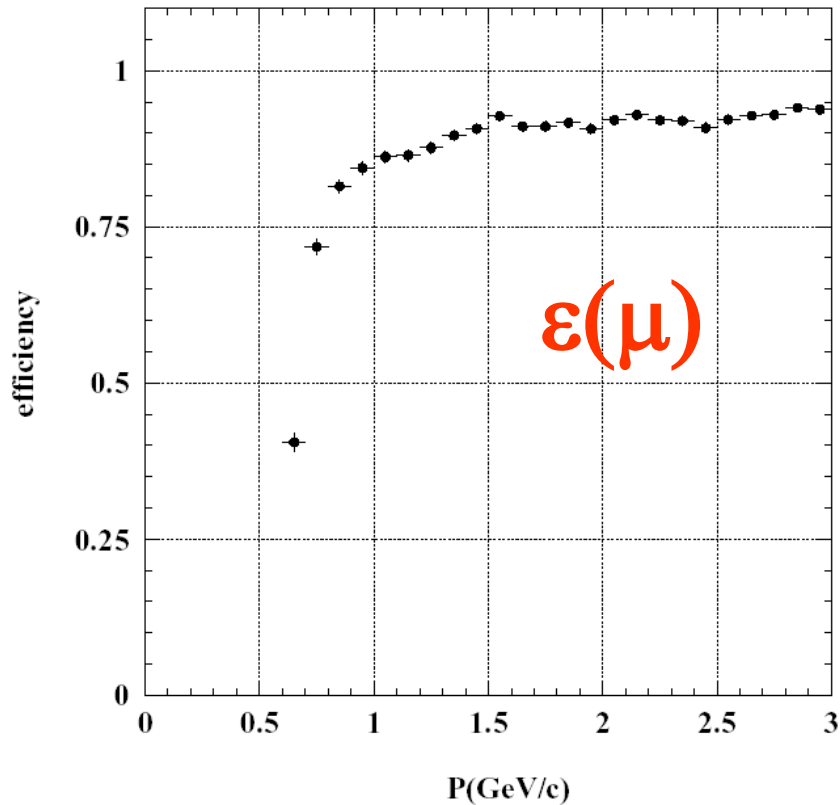

Fig. 109. Muon detection efficiency vs. momentum in KLM.

fake probability

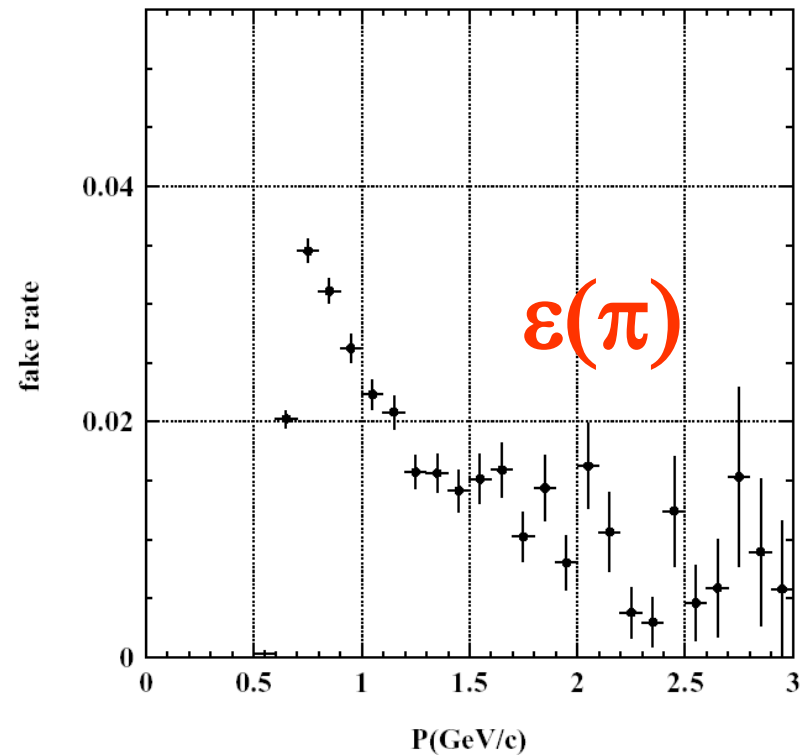
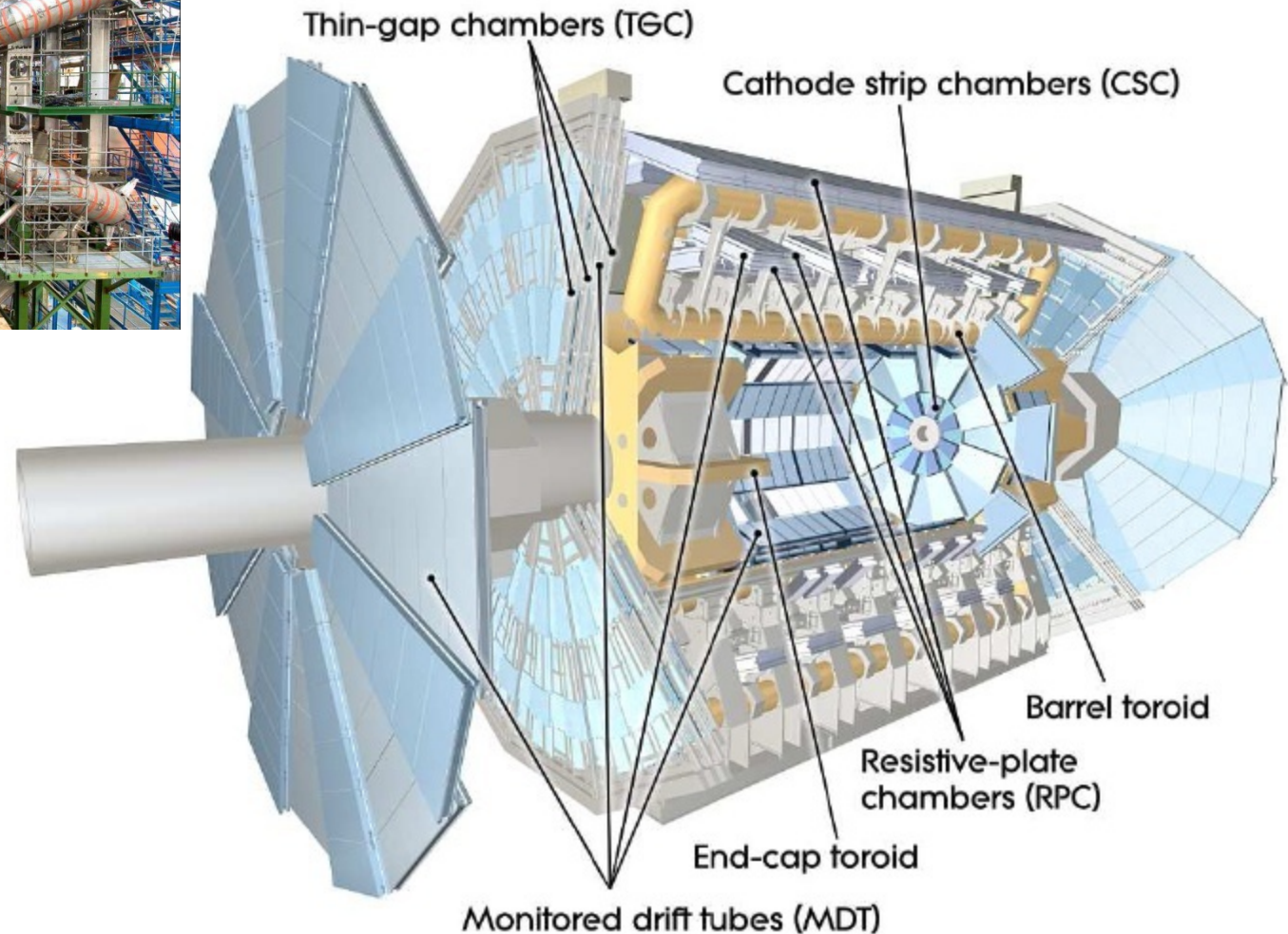
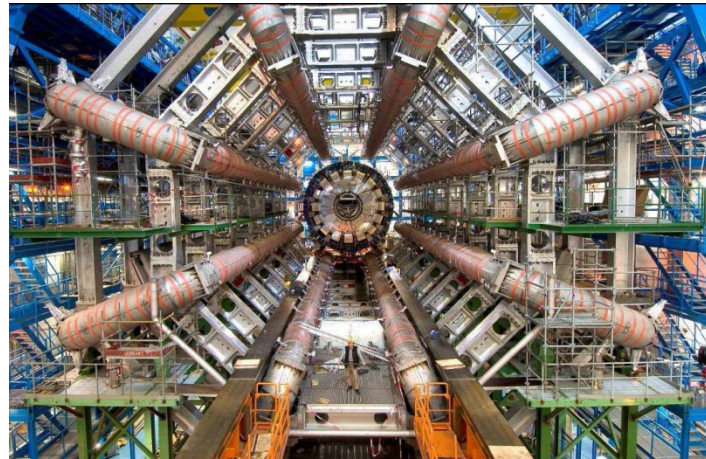

Fig. 110. Fake rate vs. momentum in KLM.



# Identification of muons in ATLAS



- Identify muons
- Measure their momentum

# Identification in astro-physics/astroparticle physics - 1

---

- Study composition of cosmic rays in balloon or satellite flights
- Identify (very) high energy cosmic rays and photons with detectors on the ground

# Short flight small area detectors (Balloons)

## Examples of Balloon-flown RICH detectors

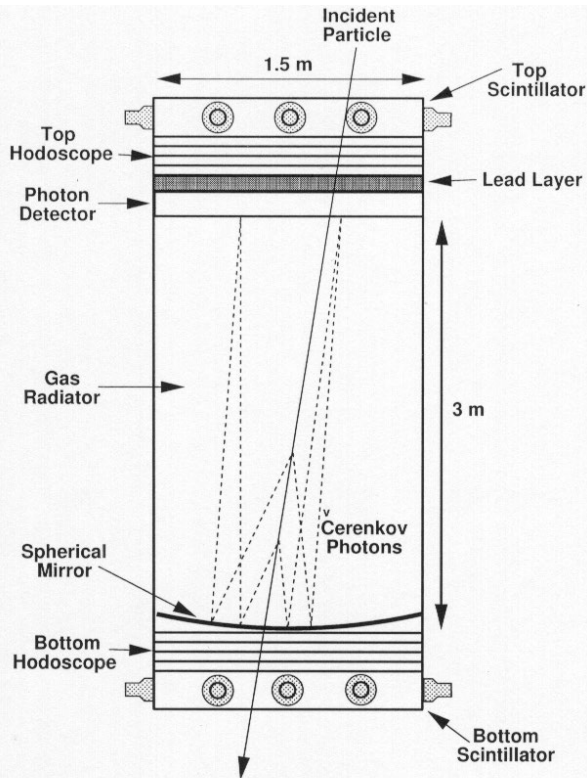
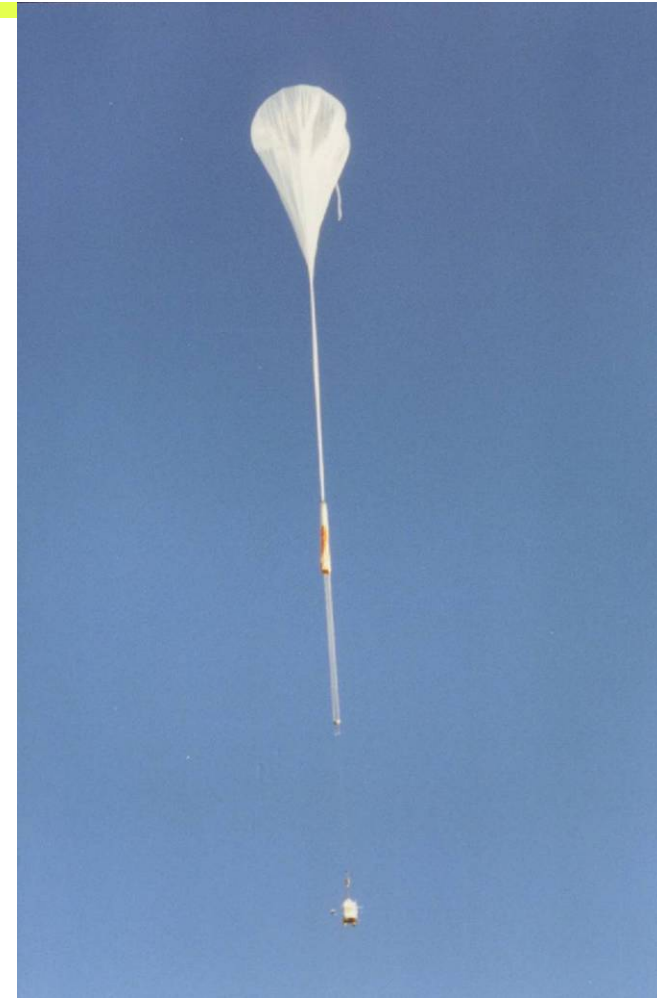
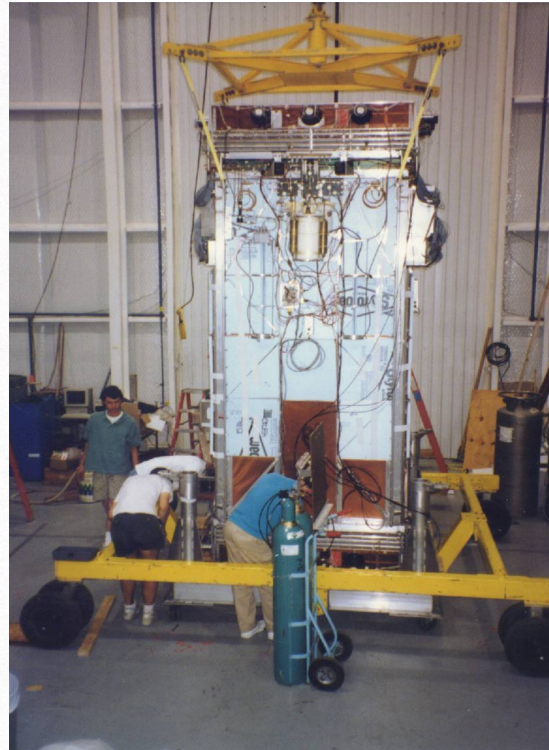
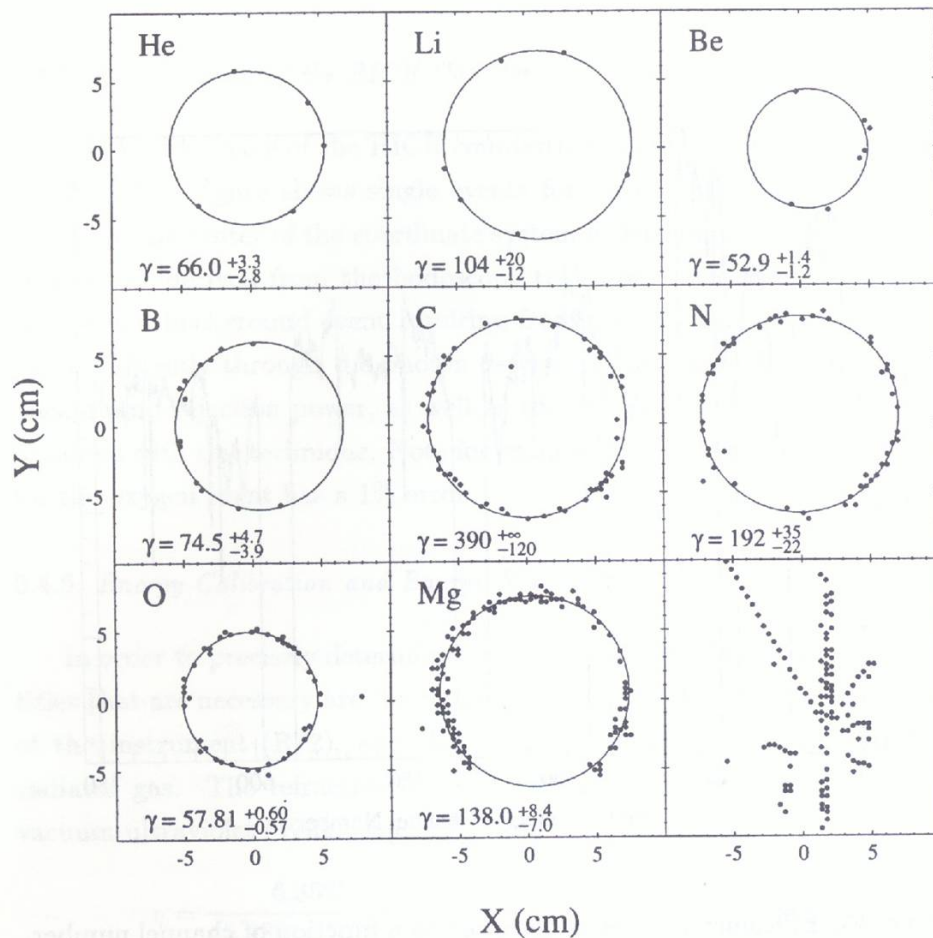

Fig. 1. Schematic cross-section of the instrument



**3-metre  $N_2$  radiator, TMAE/ $CH_4$ :  $\gamma_{th}=40$**   
**p + He at high energy:**

**3-metre  $C_2F_6$  radiator, TMAE/ $C_2H_6$ :  $\gamma_{th}=25$**



Number of  
Chrenkov photons:  
proportional to  $Z^2$

**Heavy nucleus rings from 1991 flight –  
Note that carbon here has total energy  
 $\sim 12 \cdot 390 \text{ GeV} = 4.6 \text{ TeV}$**