

Silicon photomultiplier as a detector of Cherenkov photons

S. Korpar^{a,b}, H. Chagani^a, R. Dolenc^a, P. Križan^{a,c}, R. Pestotnik^a,
A. Stanovnik^{a,c}, I. Adachi^d, T. Iijima^e

^a J. Stefan Institute, ^b University of Maribor,

^c University of Ljubljana, ^d KEK, ^e Nagoya University

October 19 – 25, 2008

NSS 2008, Dresden

Outline:

- Aerogel RICH for Super Belle
- SiPM RICH
- Beam test set-up and results
- Summary

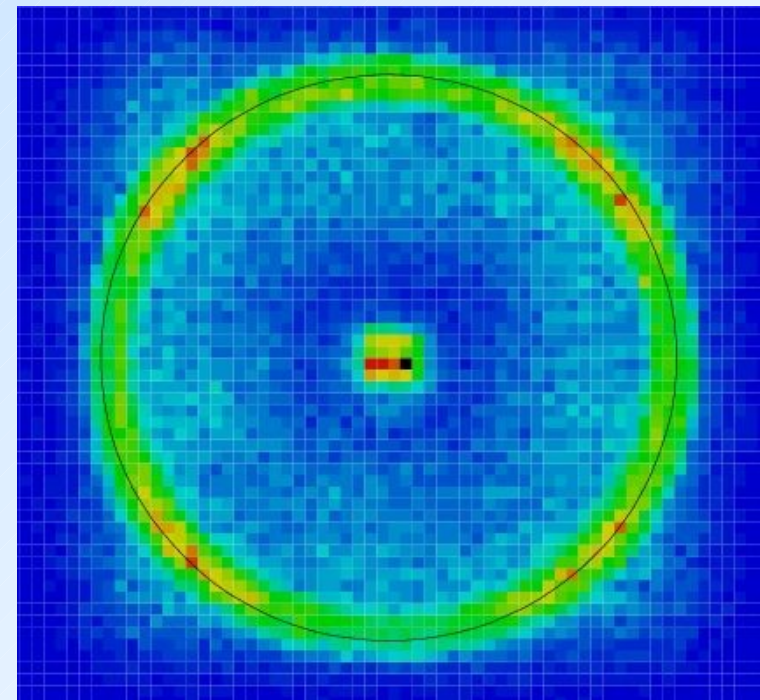

RICH for Super Belle forward PID

Selected type: proximity focusing aerogel RICH

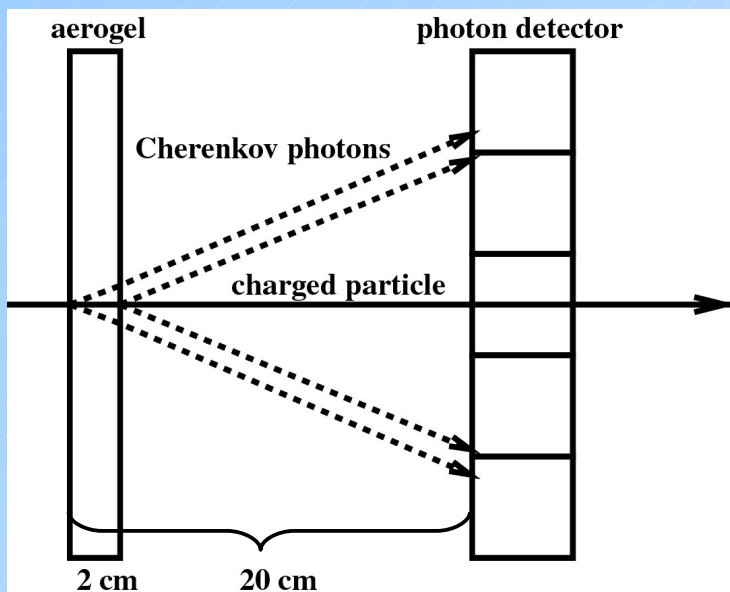

- $n \sim 1.05$ ($\vartheta_c(\pi) = 308$ mrad and $\Delta\vartheta_c(\pi, K) = 23$ mrad @ 4 GeV/c)
- limited space - distance from aerogel entrance window to photon detector ~ 200 mm
- operation in magnetic field 1.5 T
- photon detector candidates: HAPD, MCP-PMT, **SiPM**

Tests with 4x4 array of flat panel PMTs and 2cm+2cm focusing aerogel radiator:

- $N_{ph.} \sim 10$
- $\sigma_{single} = 14$ mrad
- $\sigma_{track} = 4.6$ mrad
- **5 σ at 4GeV/c**

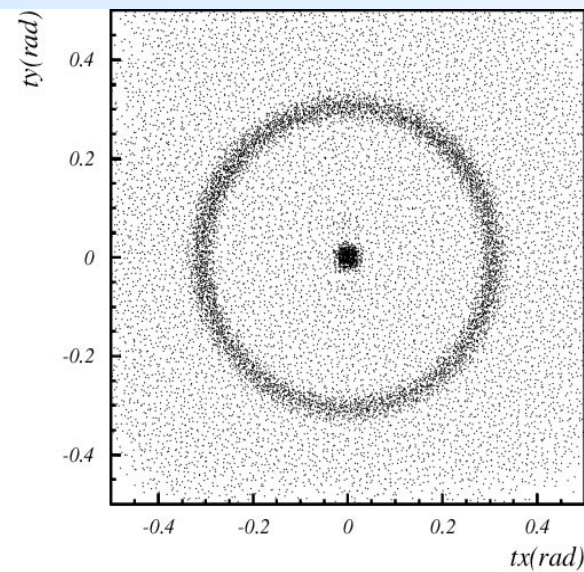
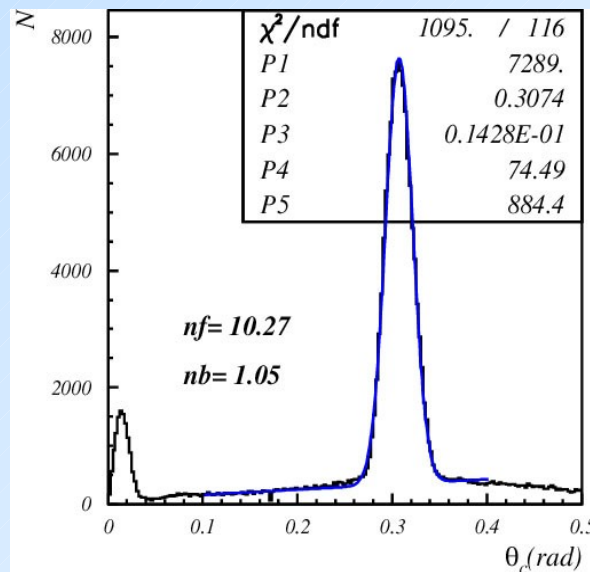
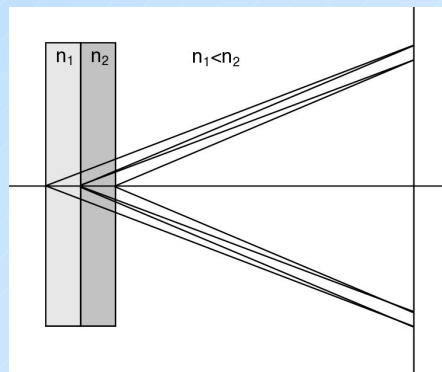

SiPM characteristics

- works in magnetic field
- low operation voltage $\sim (10-100)V$
- peak PDE ($= QE \times \epsilon_{\text{geiger}} \times \epsilon_{\text{geo}}$) up to 65% (@400nm - Hamamatsu data sheet)
- gain $\sim 10^6$
- time resolution $\sim 100-200$ ps
- dark counts \sim few $100\text{kHz}/\text{mm}^2$
- radiation damage (p,n)

Can such a device be used in a RICH?

- detection of single photons
- linearity is not needed
- HC100 is preferred due to higher efficiency

First successful tests with cosmic rays
NIM A594 (2008) 13

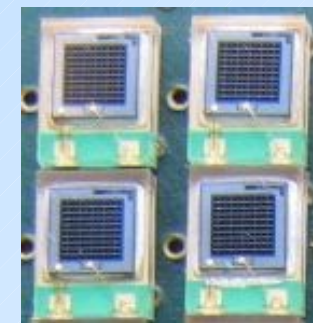
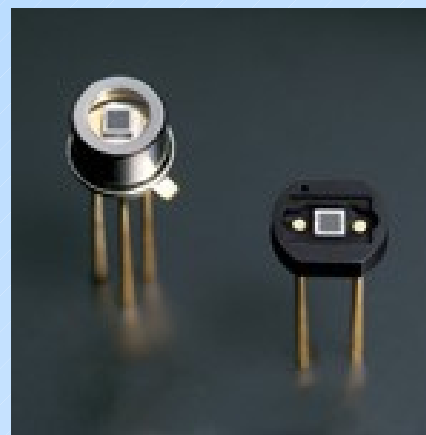

Hamamatsu: HC100, HC050, HC025 (Ta=25 °C)

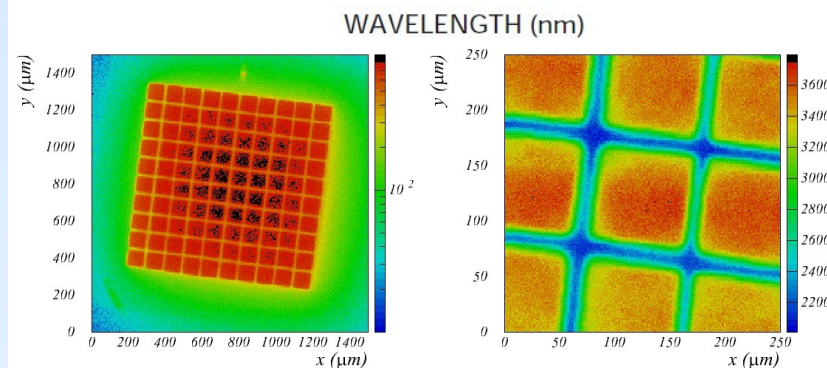
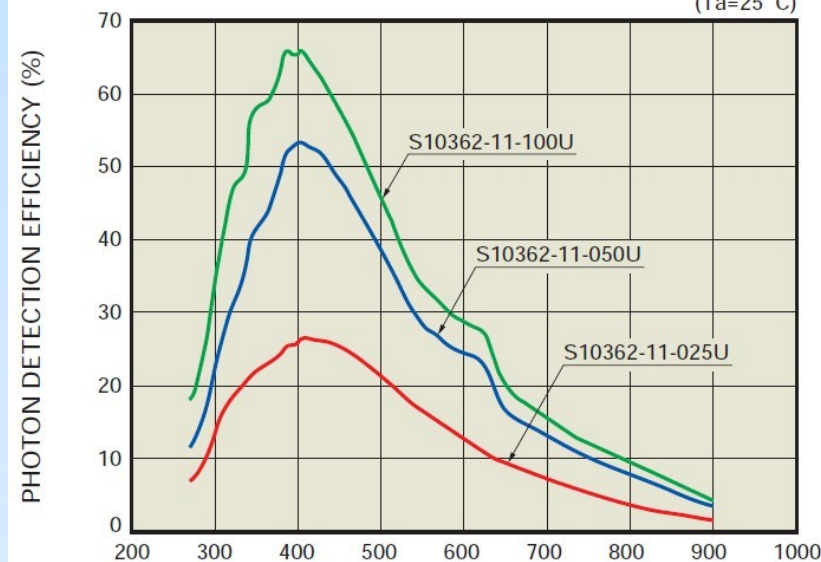

SiPM characteristics 2

Typical pulse height distribution:

- signal is well separated from pedestal level
- single photon pulses are the same as dark current pulses

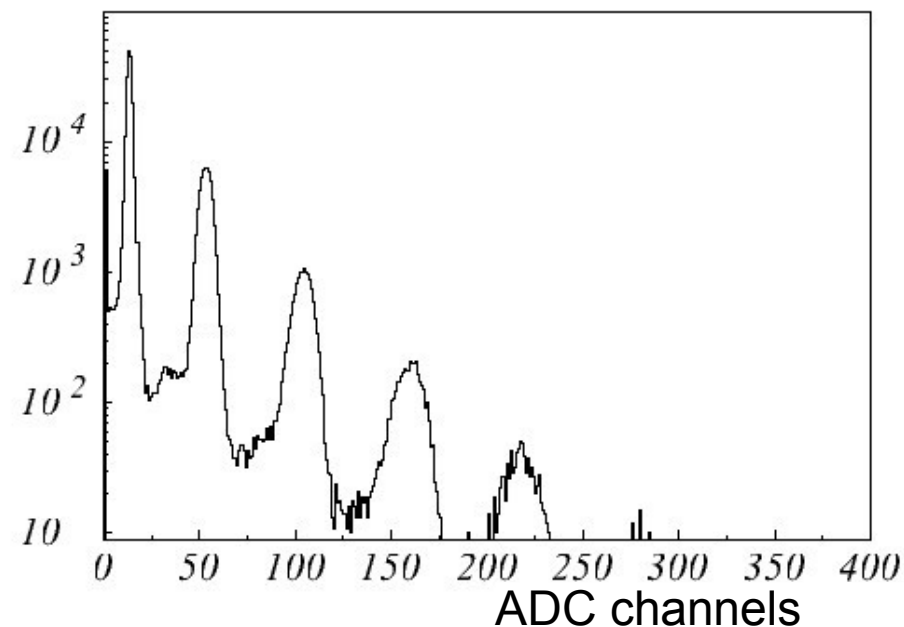

Typical timing distribution:

- narrow time window can be used to separate Cherenkov photons from dark current pulses

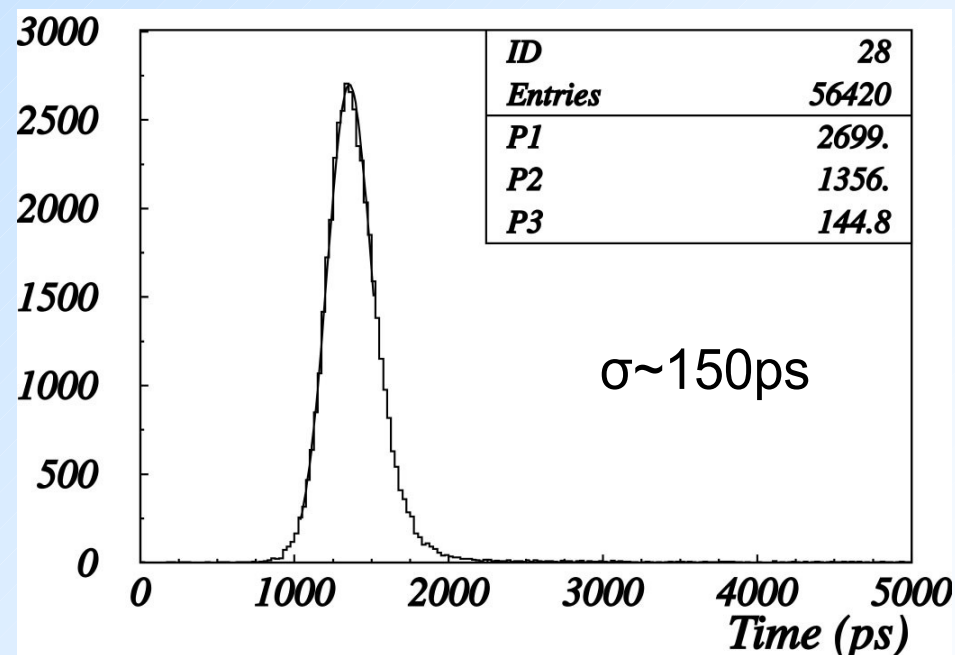

Expected number of photons

Expected number of photons for aerogel RICH (beam test prototype):

- multianode PMTs (peak QE ~ 25%, collection eff. ~ 70%) or MPPCs (HC100)
- aerogel radiator: thickness 1 cm, n = 1.03 and transmission length 2.5 cm (@400nm)

$$N_{\text{SiPM}}/N_{\text{PMT}} \sim 4$$

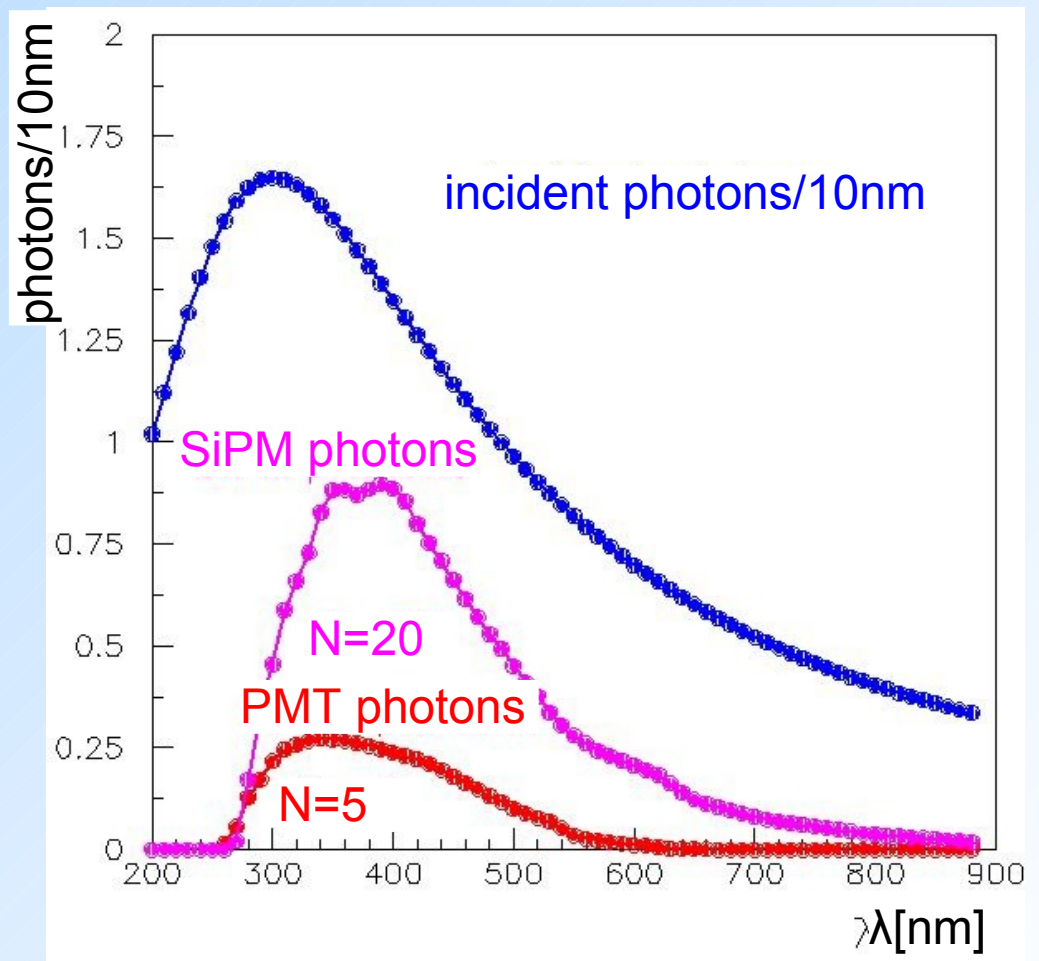
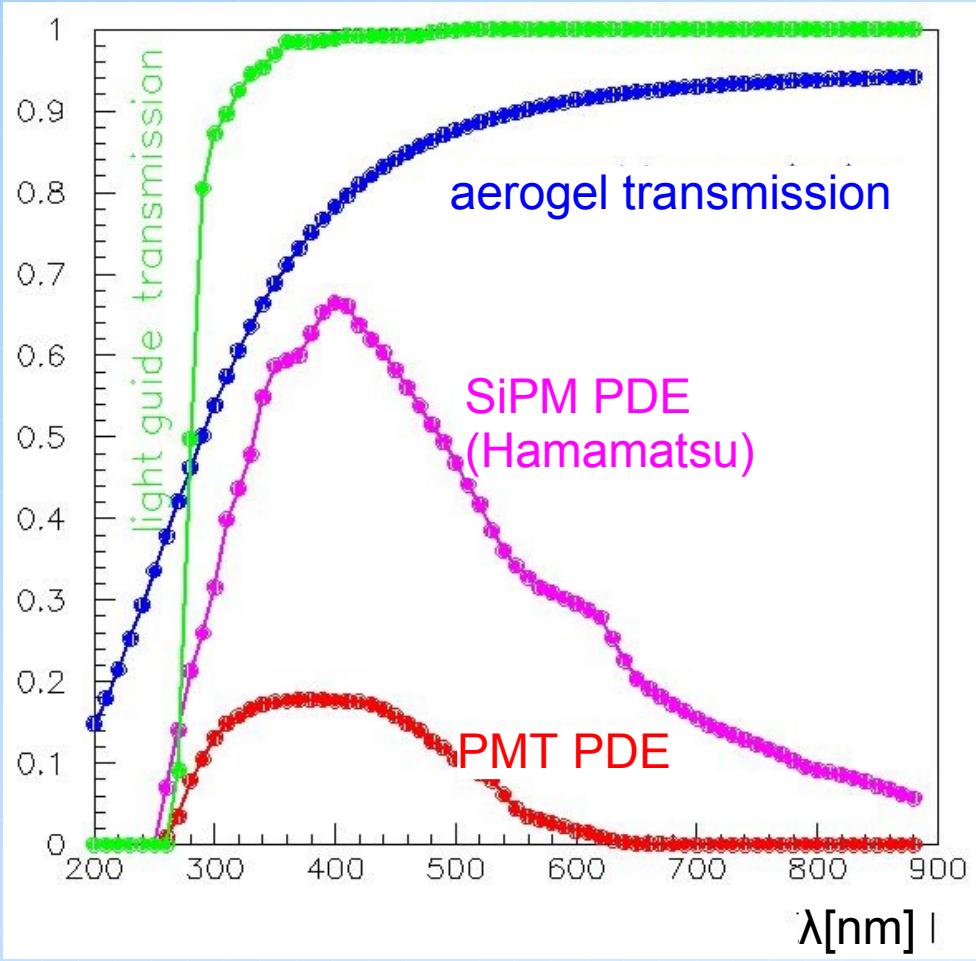

Signal to noise

Expected number of background hits depends on:

- ring area $\sim 2000 \text{ mm}^2$
- dark count rate $\sim 600 \text{ kHz/mm}^2$
- coincidence window $\sim 5 \text{ ns}$

$$N_{\text{dark}} \sim 6 \rightarrow N_{\text{ph}}/N_{\text{dark}} \sim 3.3$$

Ratio can be increased by:

- smaller ring image area
- narrower time window
- use of light collection system (light guides) to increase effective area of the sensor

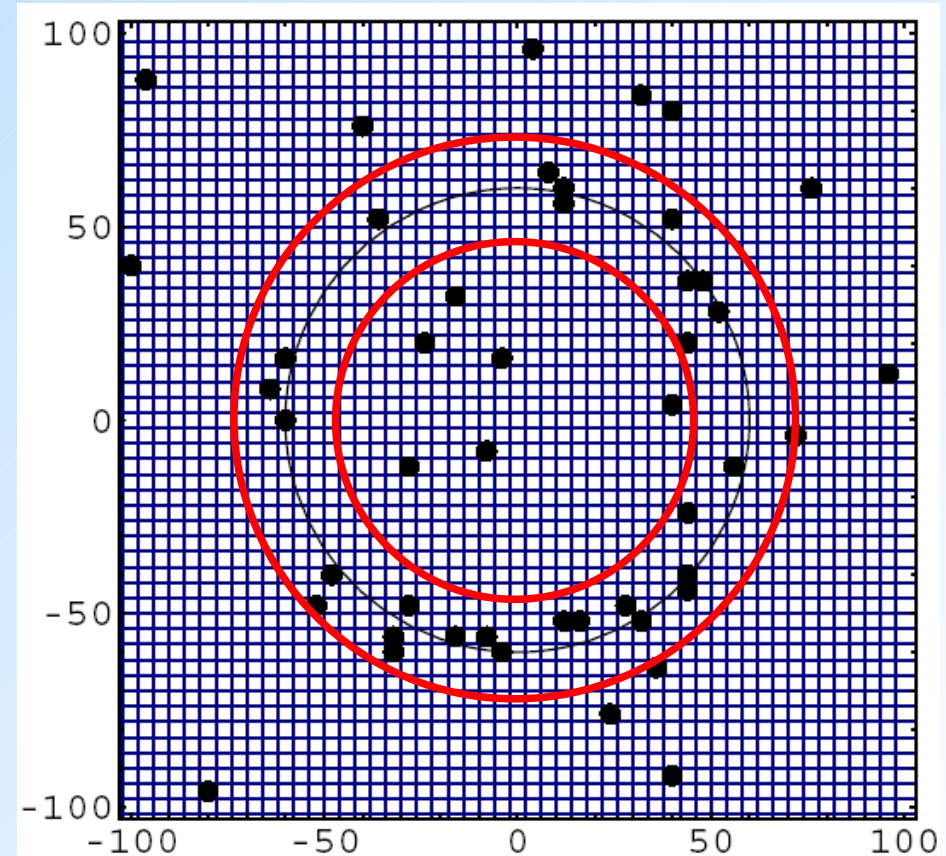
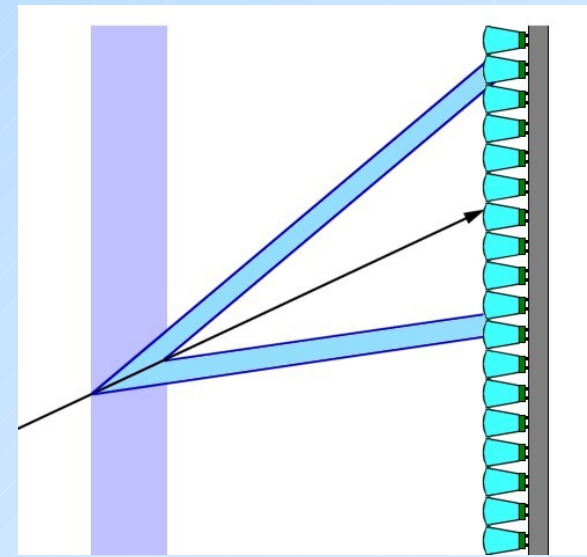

8x8 array of SMD-MPPCs

- Detector module with 8x8 array of SMD MPPCs at 2.54 mm pitch

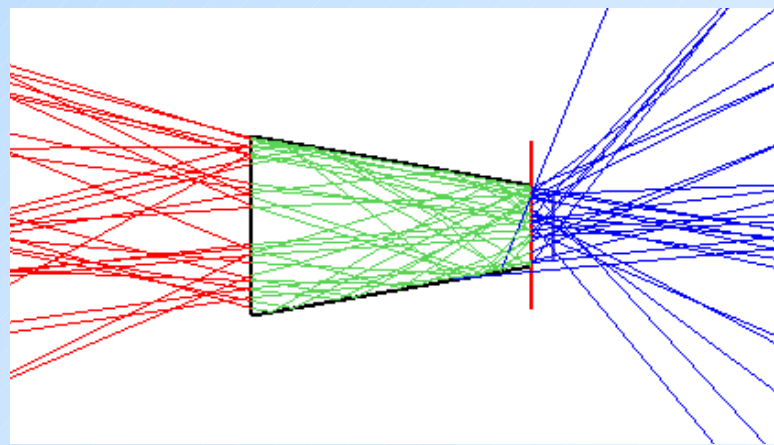
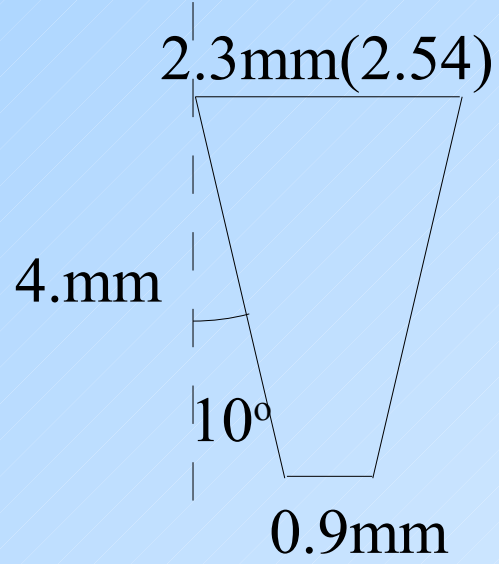
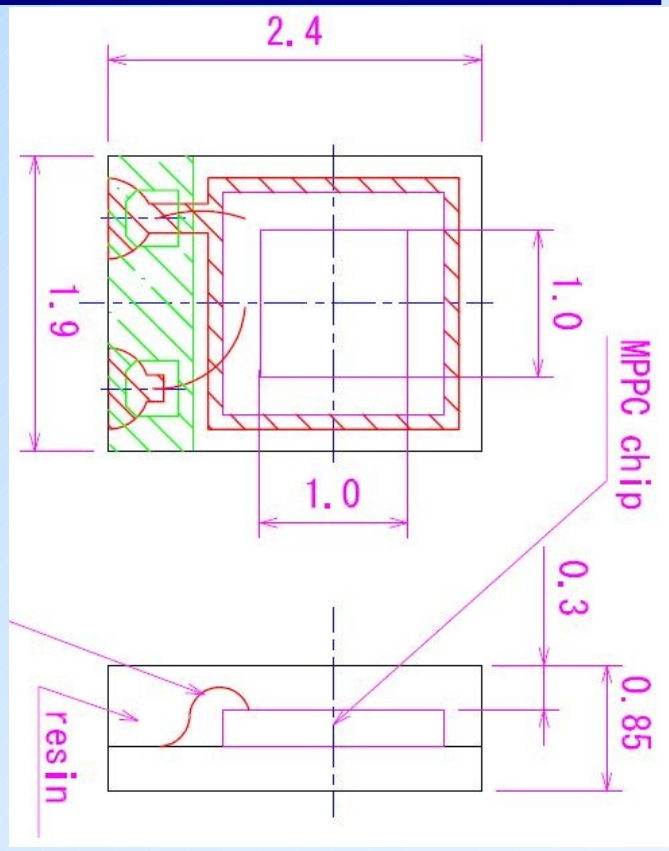
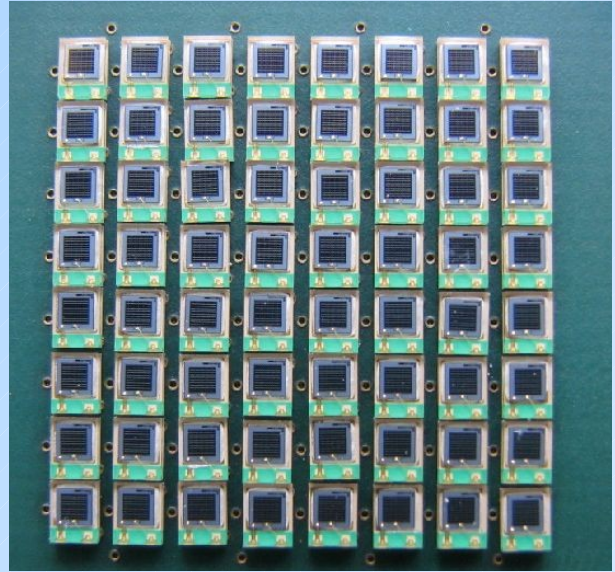
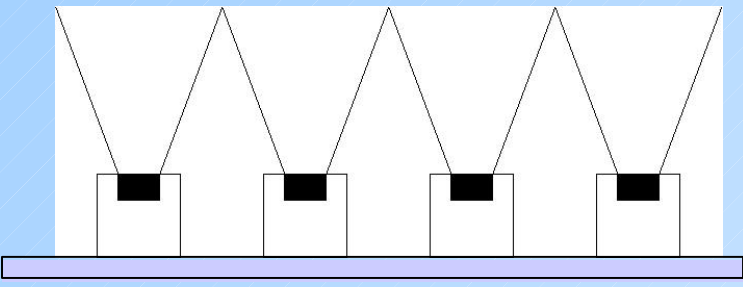

Light guides were machined from plastic (HERA-B lens material).

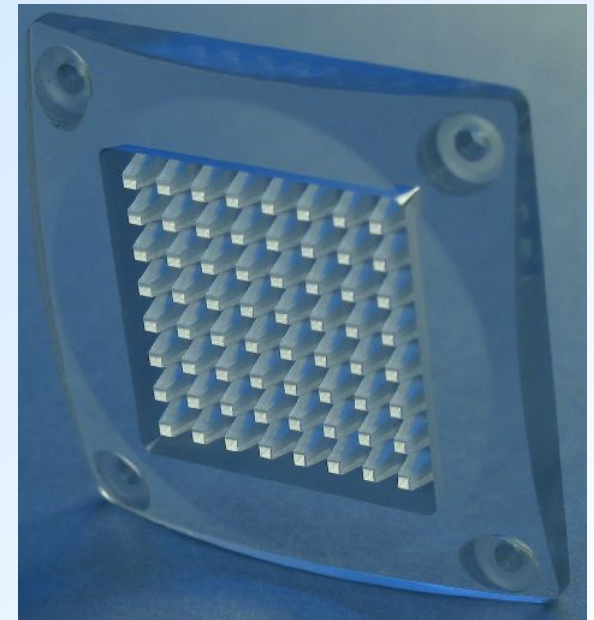

MPPC module

- main board with dividers, bias and signal connectors
- piggy back board with MPPCs (8x8 array of HC100 in SMD package; background ~ 400kHz/MPPC)
- light guides
- 16 electronics channels (4x4) - 4 MPPCs connected to single channel

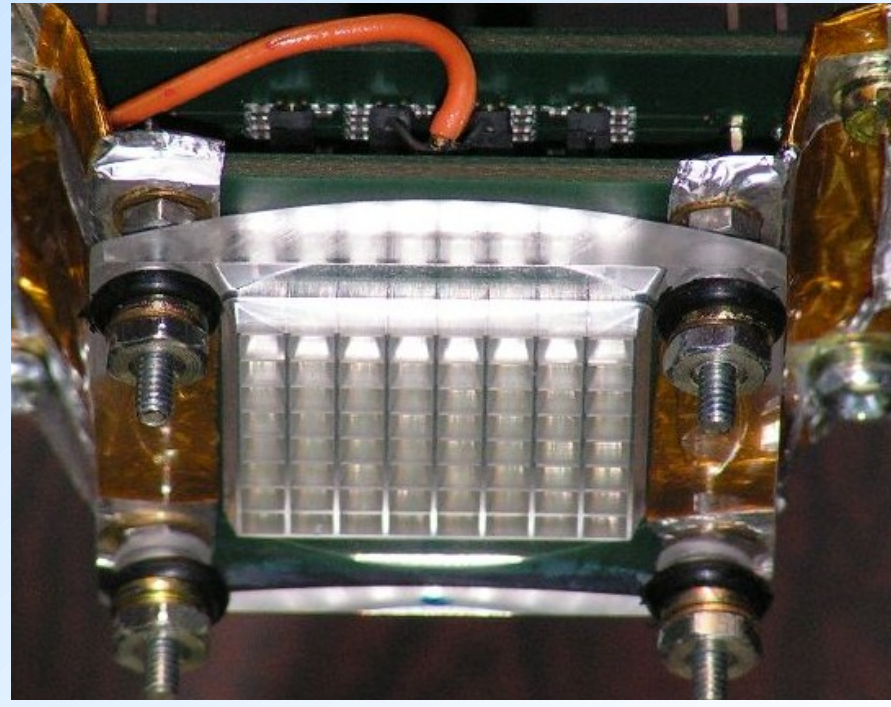
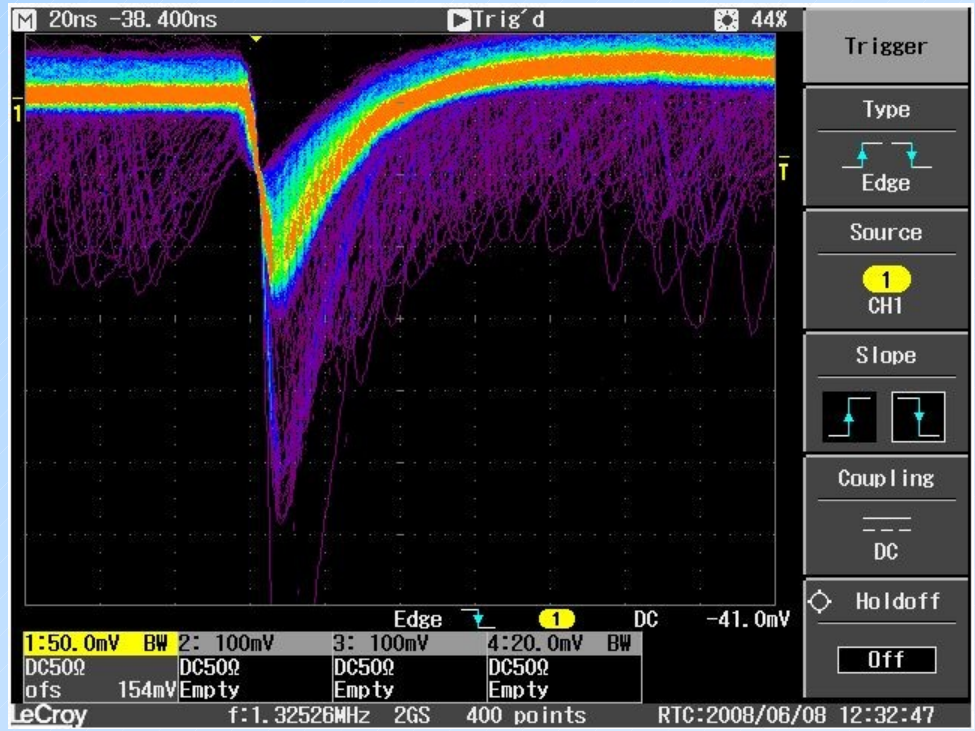
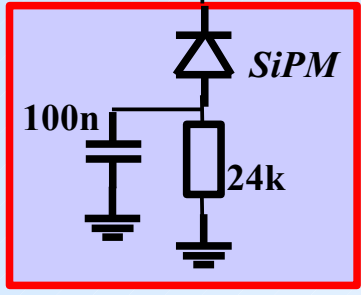
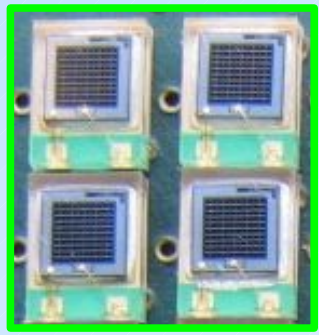
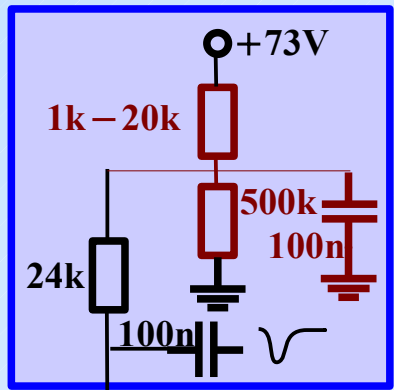

MPPC module 2

- pad size 5.08 mm, 4 mm² active (15.5% w/o LG)

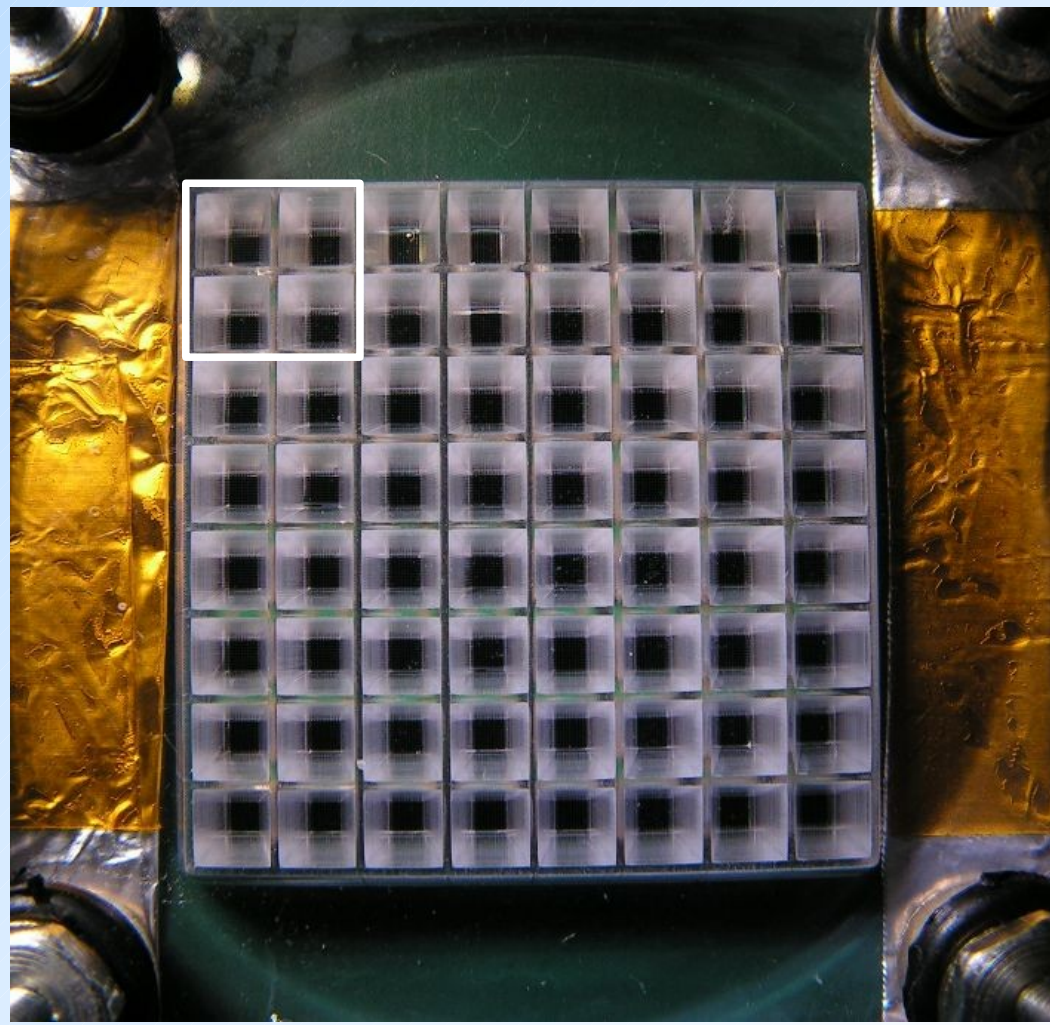
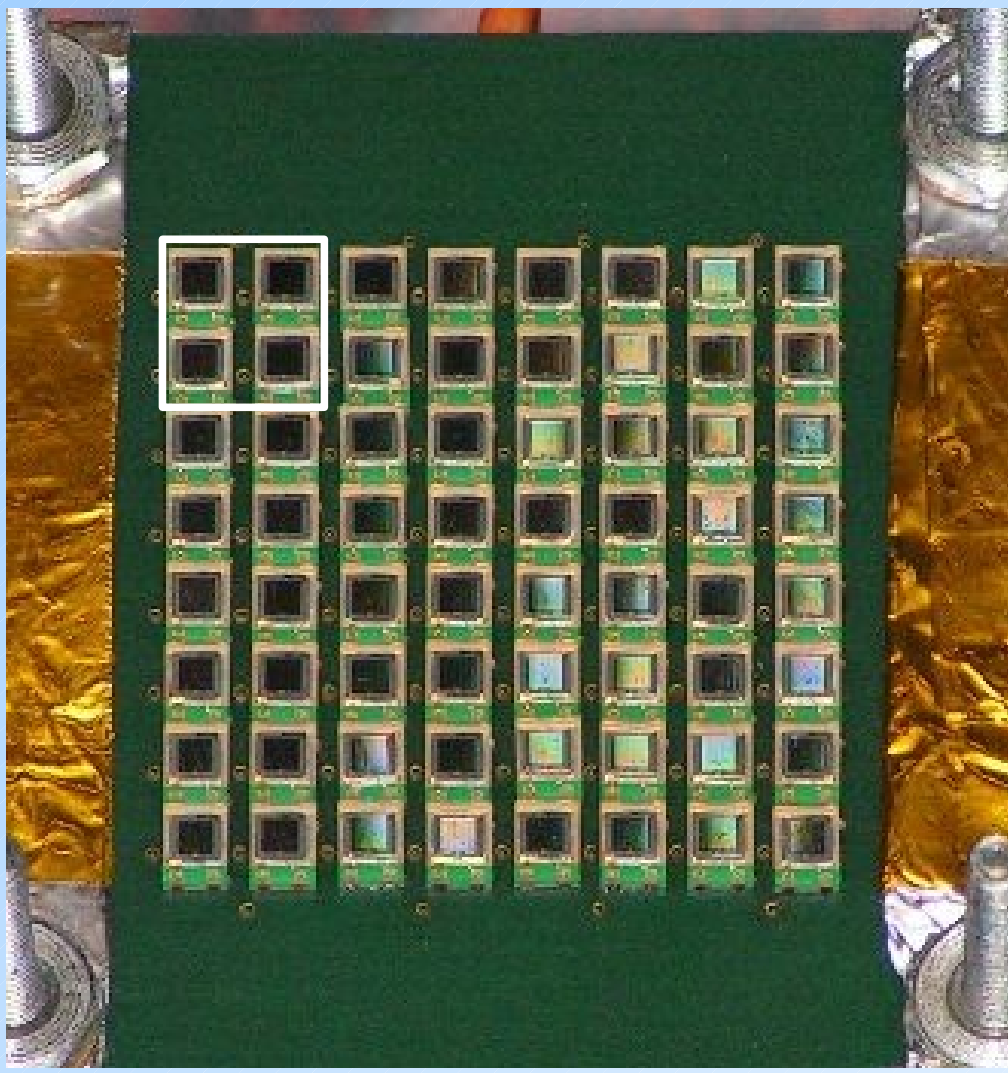

Beam test setup

- 2 MWPCs for tracking and scintillator for timing
- MPPC array w/o or w/ light guide mounted on 3D stage
- aerogel $n=1.03$, $d=10\text{mm}$ (distance 130mm)
- hits detected by multi-hit TDC
- $+120\text{ GeV}/c$ pions, beam size $\sim 1\text{cm}^2$

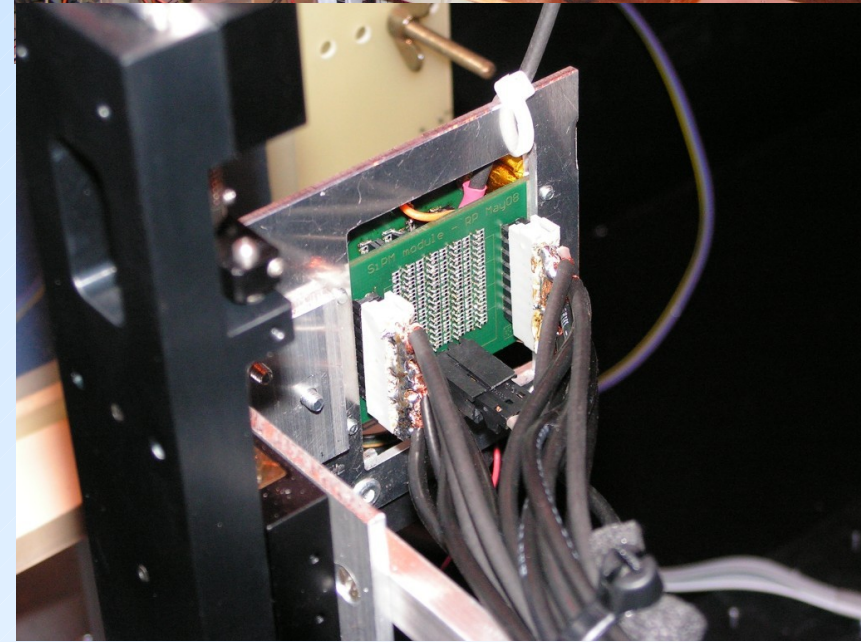
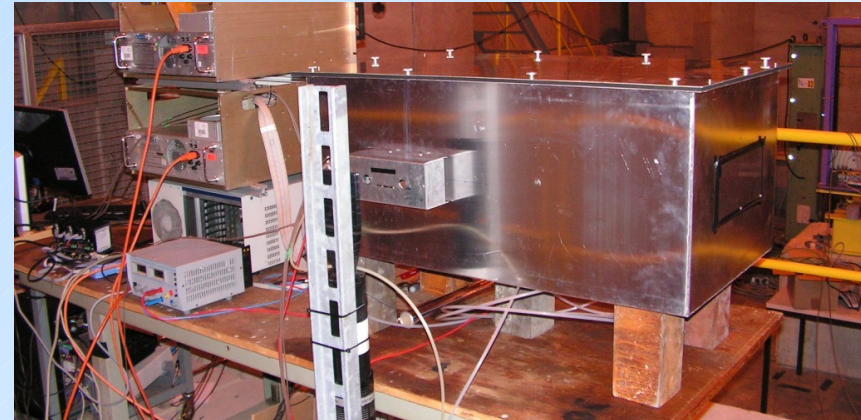
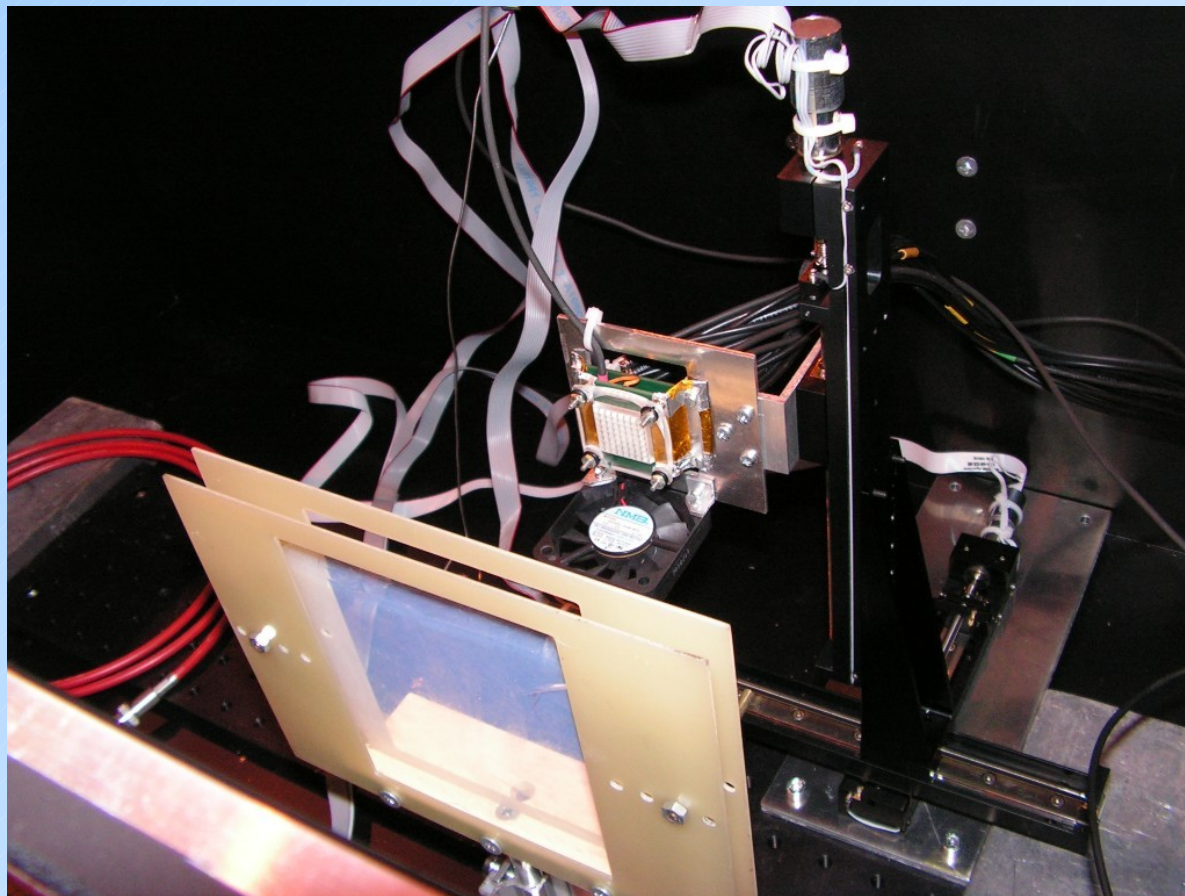

TDC distributions of MPPC hits for all events

- total noise rate $\sim 35\text{MHz}$ ($\sim 600\text{kHz/MPPC}$)
- hits in the time window of 5ns around the peak are selected for Cherenkov angle analysis

w/o light guides

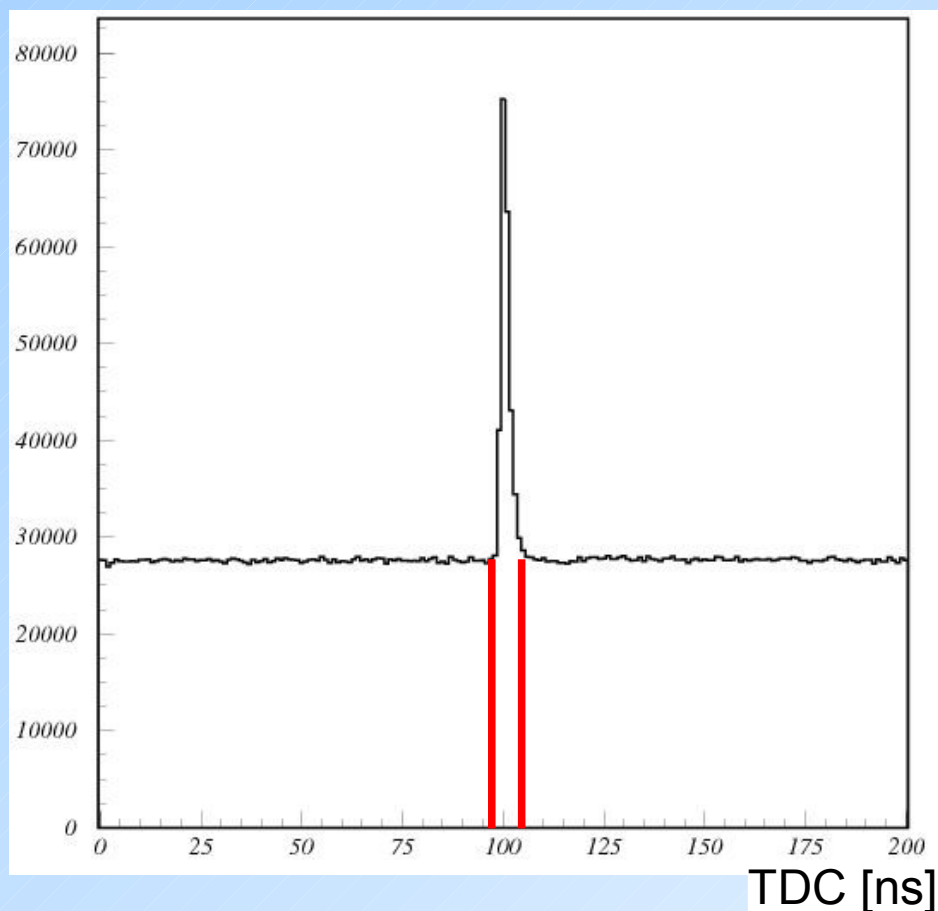

w/ light guides

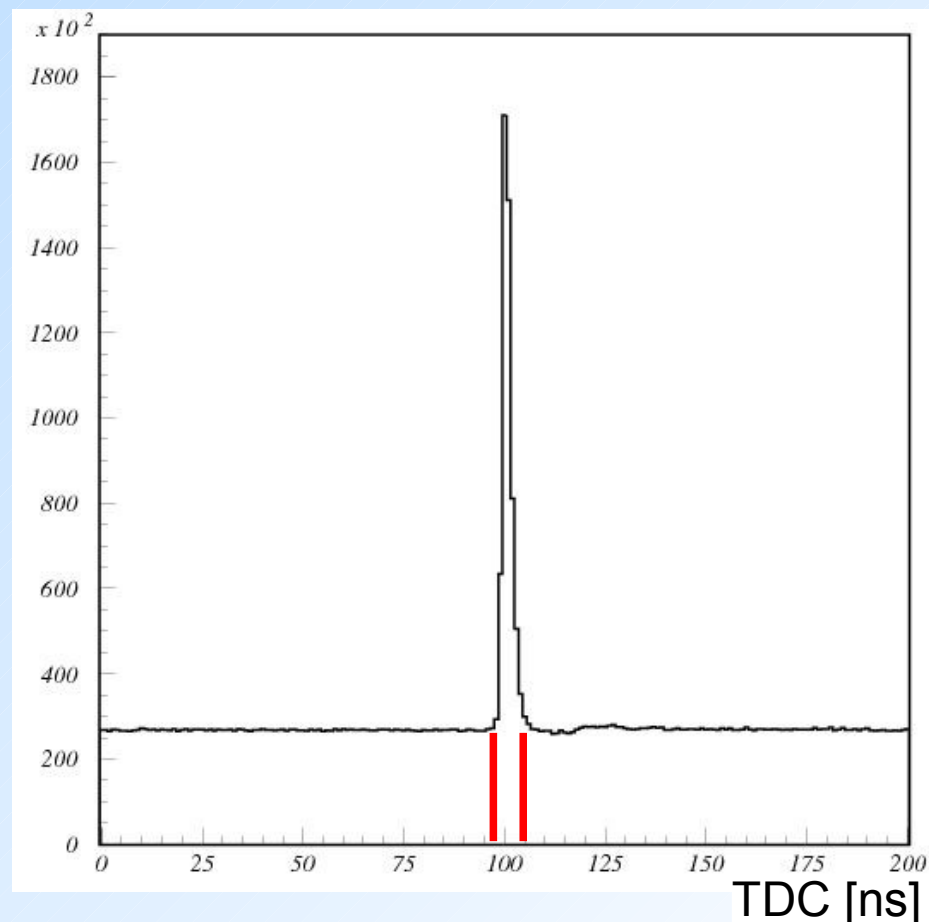

Ring images

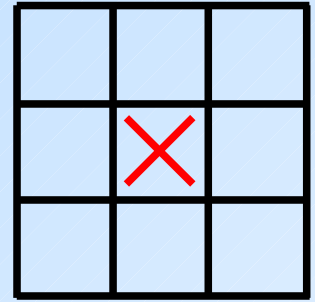

- module was moved to 9 positions to cover the ring area
- these plots show only superposition of 8 positions (central position is not included)

w/o light guides

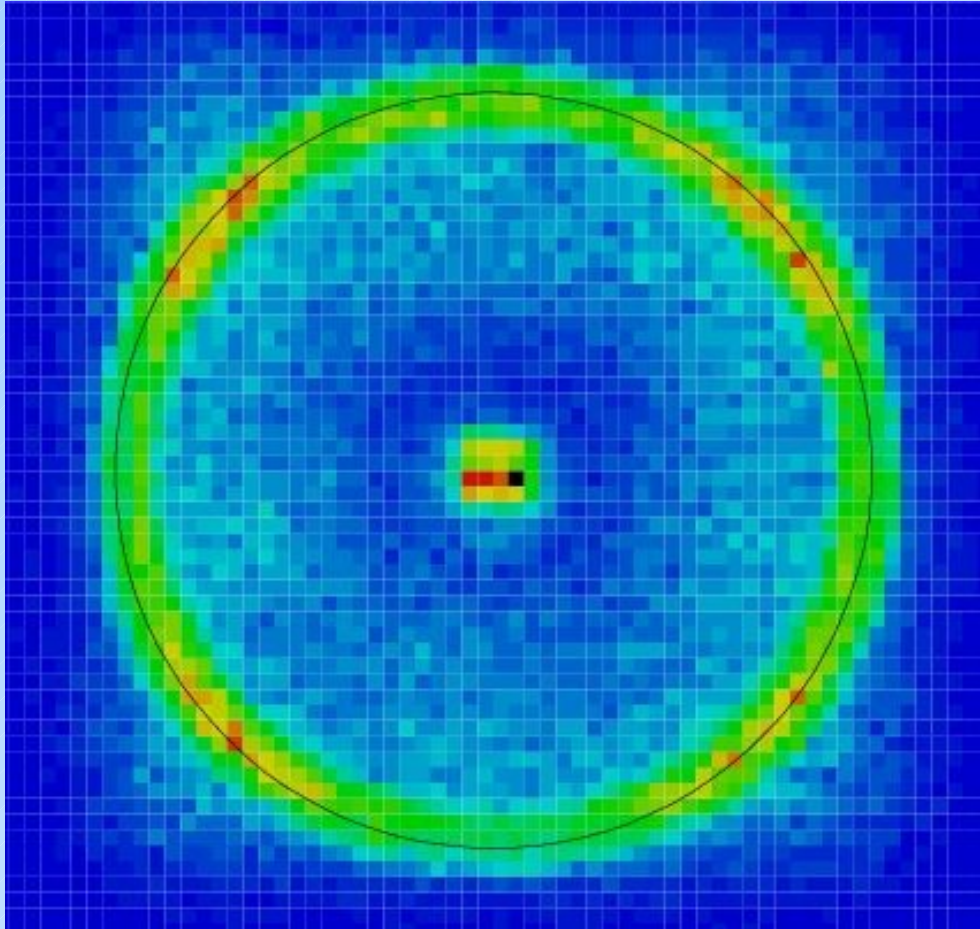

w/ light guides

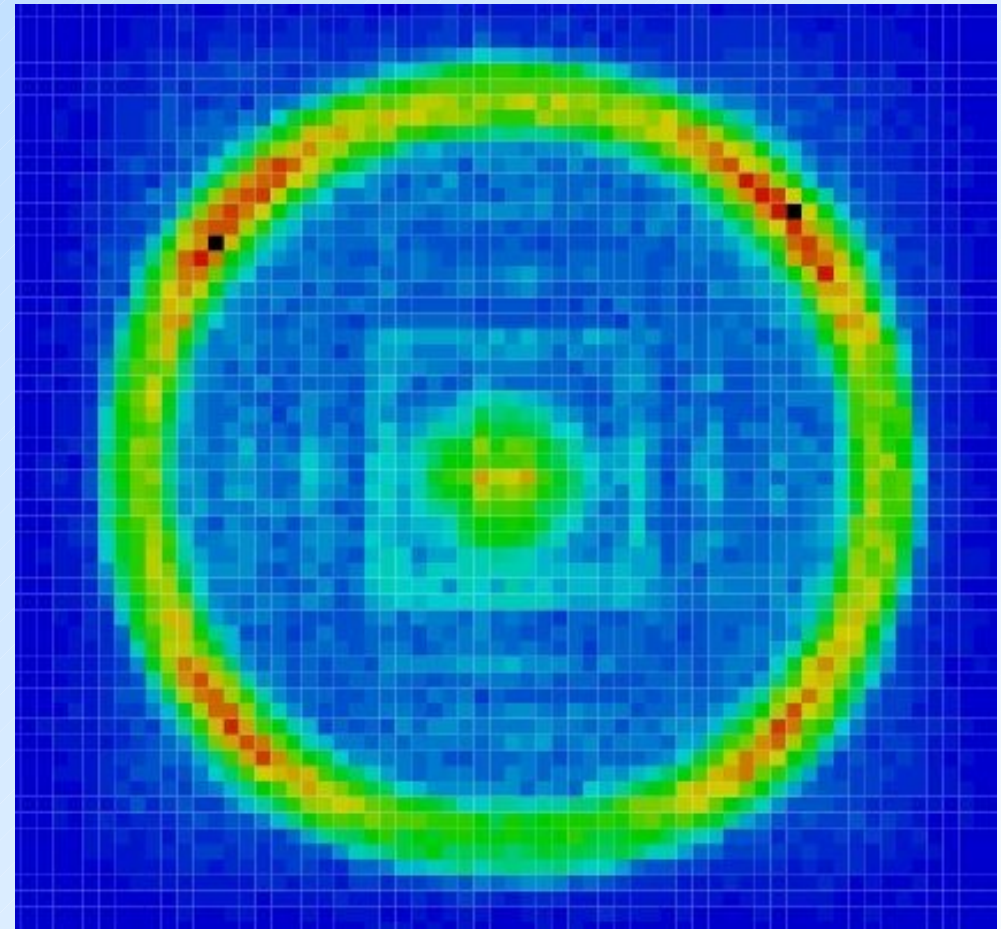

Ring images

w/o light guides

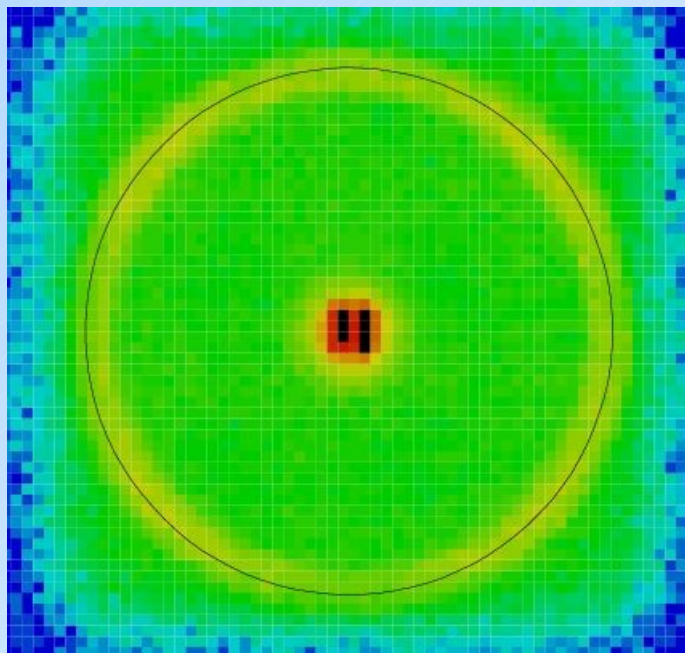
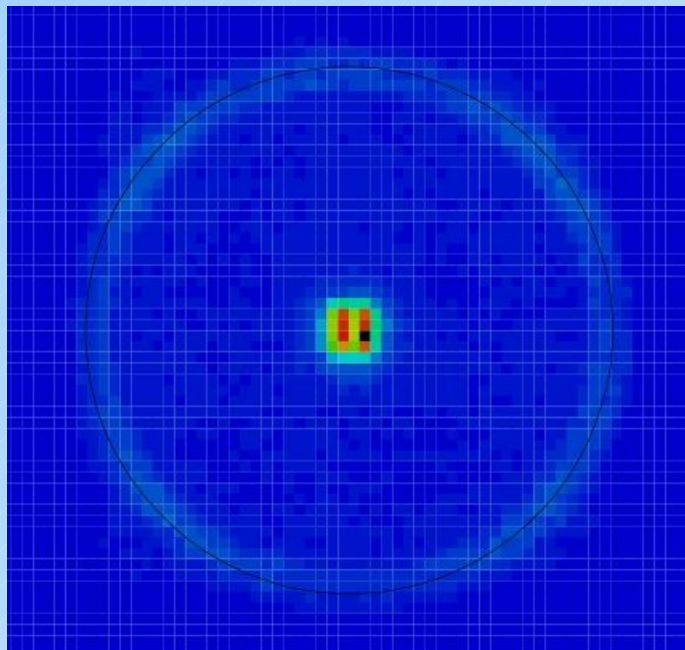

w/ light guides

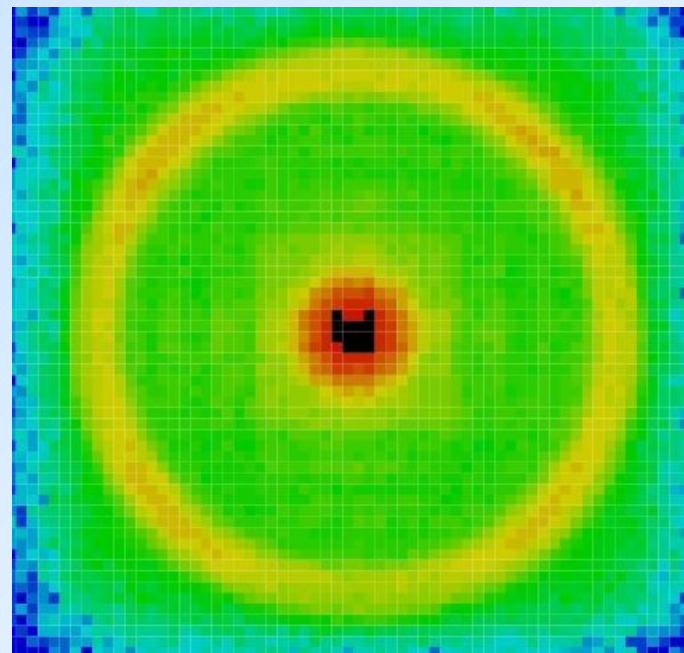
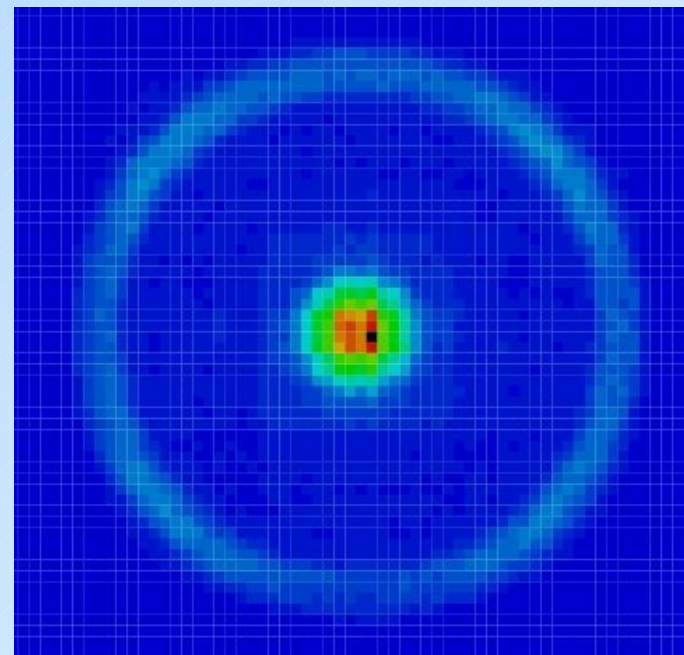

Cherenkov angle distributions

- background from SiPM noise hits is obtained from sideband in TDC distribution

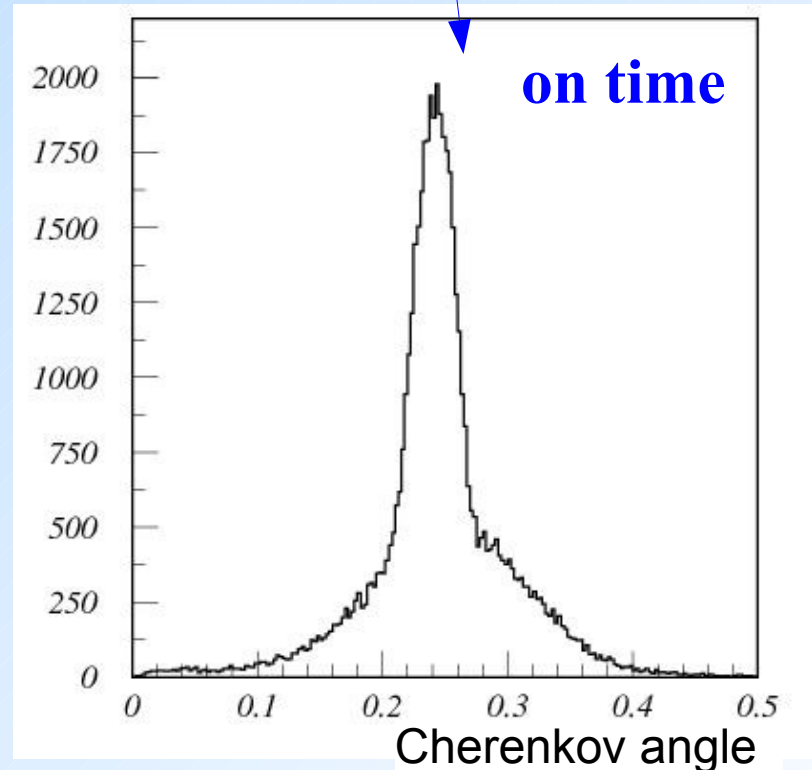
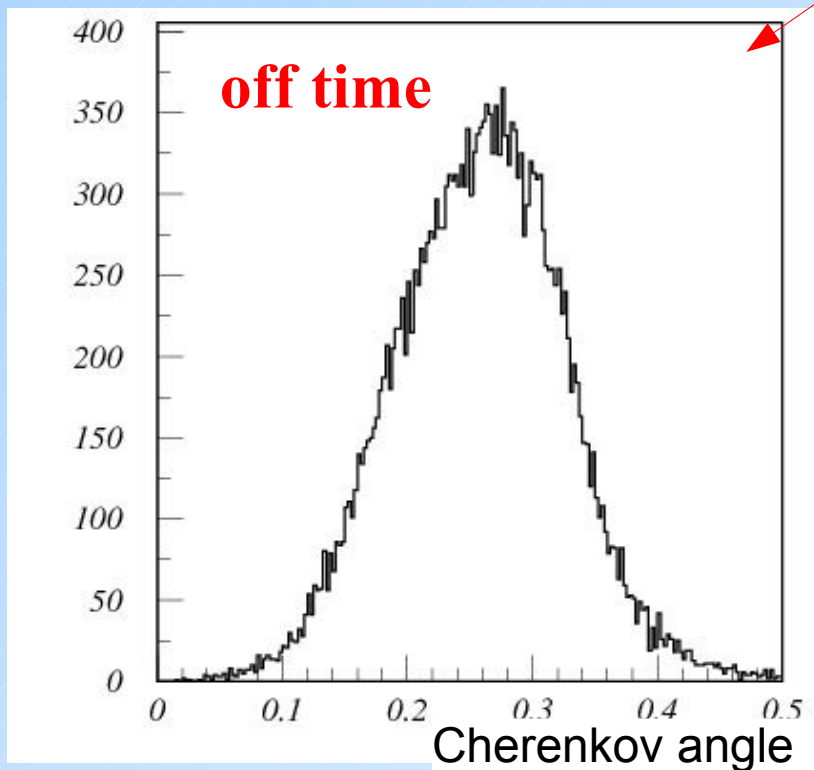
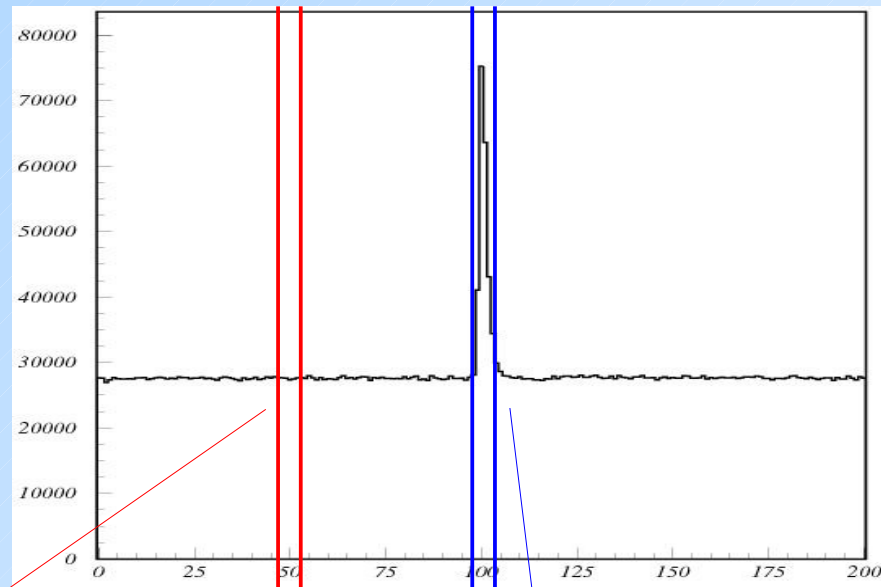

Cherenkov angle distributions

- background subtracted distributions
- ratio of detected photons w/ and w/o: ~ 2.3
- resolution within expectations (14.5mrad)

w/o light guides

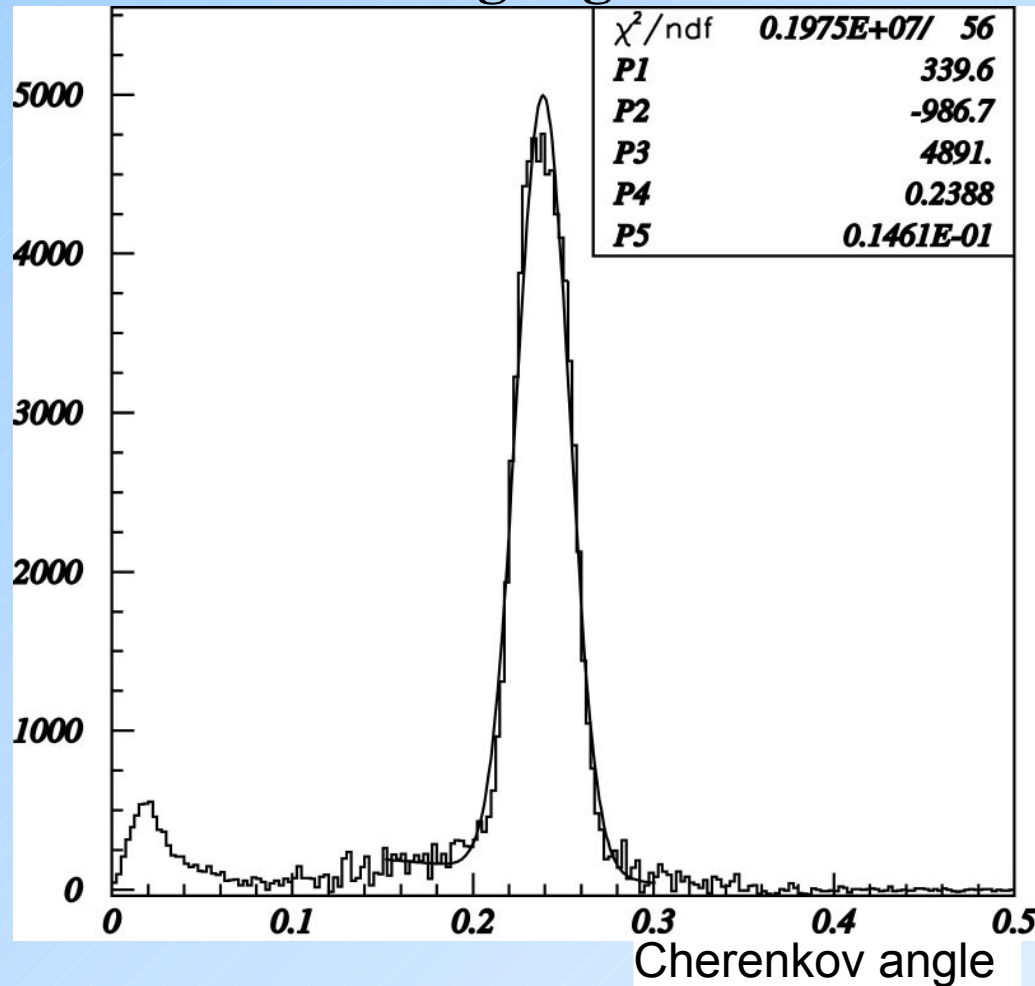

w/ light guides

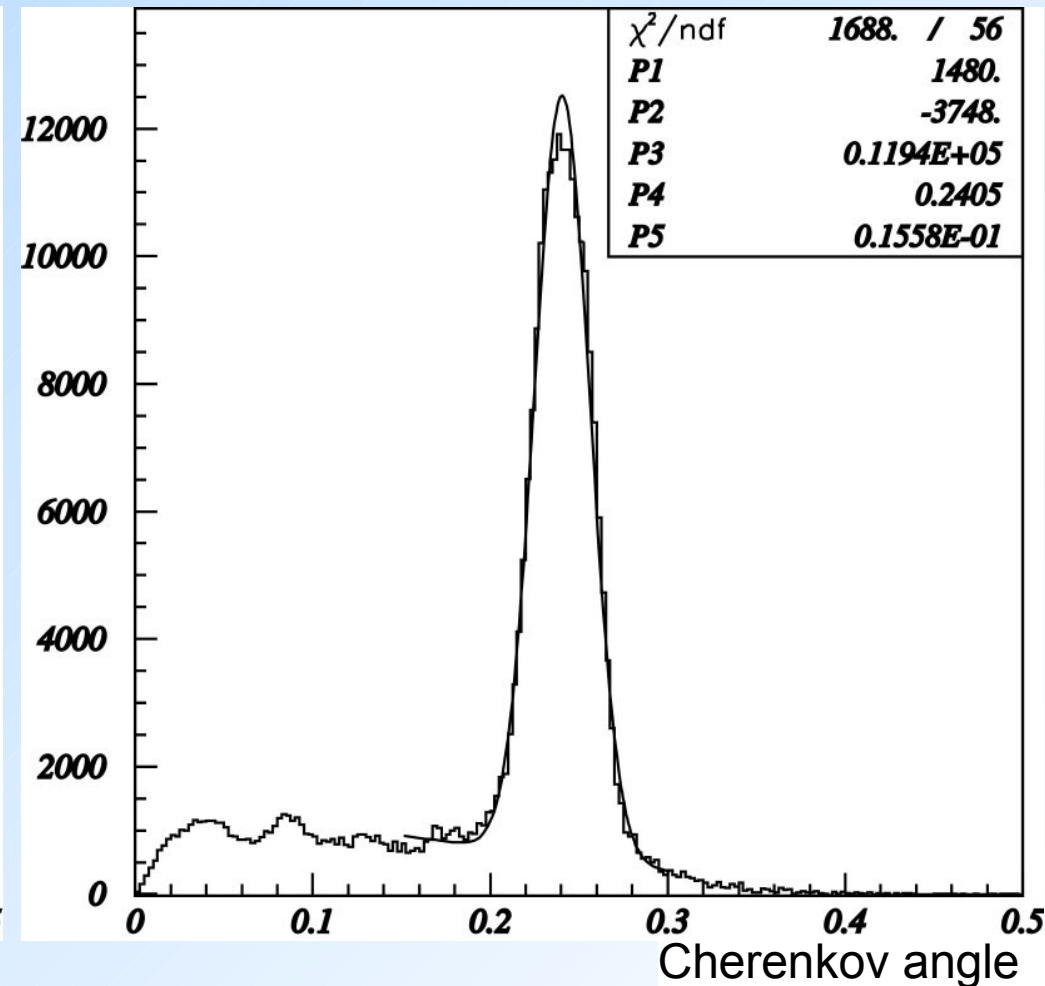

Number of photons

Expected number of photons is $\sim 3/\text{full ring}$, this includes:

- Hamamatsu PDE
- aerogel: 1cm thickness, $n=1.03$, 25mm attenuation length
- dead time and double hit loss $\sim 10\%$

Measured (extrapolated to full ring - acceptance corrected):

- w/o LG ~ 1.6
- w/ LG ~ 3.7

Estimated numbers for aerogel with $n=1.05$ and thickness of 4cm ($\sim 5x$) and better quality of light guides (surface polishing: $\sim 2x$) are

- w/o LG ~ 8
- w/ LG ~ 37

Summary

- A photon detector module was constructed using 8x8 array of MPPCs (SMD package) and a light guide array
- A proximity focusing RICH with 1cm aerogel radiator ($n=1.03$) and the detector module was successfully tested in a test beam at CERN
- The number of detected photons per ring is about half of the expected number obtained using manufacturers PDE
- Efficiency increase with light guides ~ 2.3 (area ratio ~ 5.5)
- **Silicon photomultiplier can be used as a detector of single photons in RICH counters.**

BACKUP SLIDES

Belle forward PID upgrade

Requirements and constraints:

- $\sim 5 \sigma$ K/ π separation @ 1-4 GeV/c
- operation in magnetic field 1.5T
- limited available space ~ 250 mm

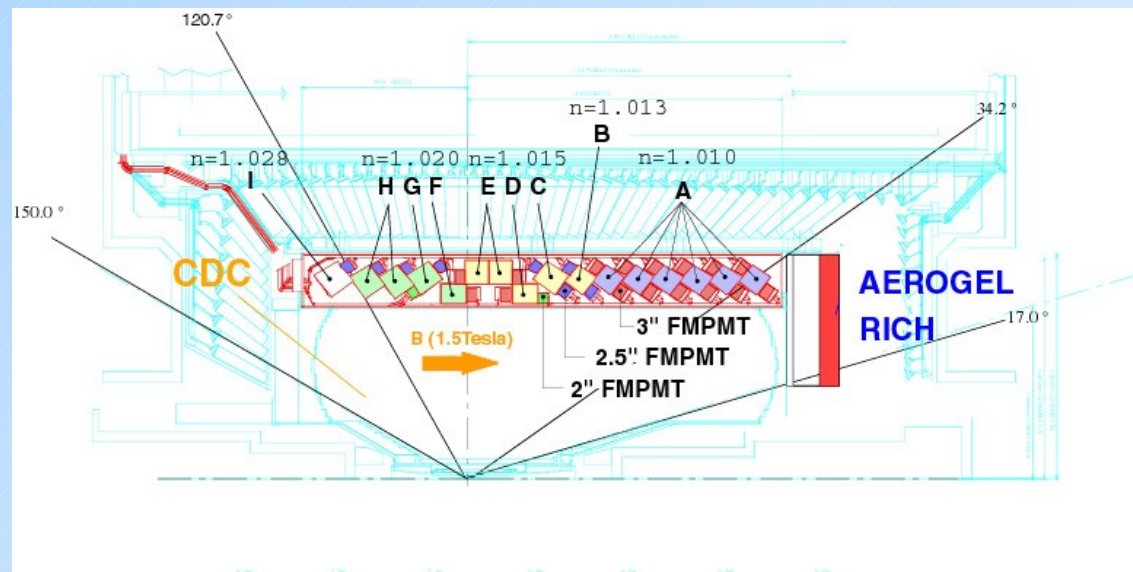

Selected type: proximity focusing aerogel RICH

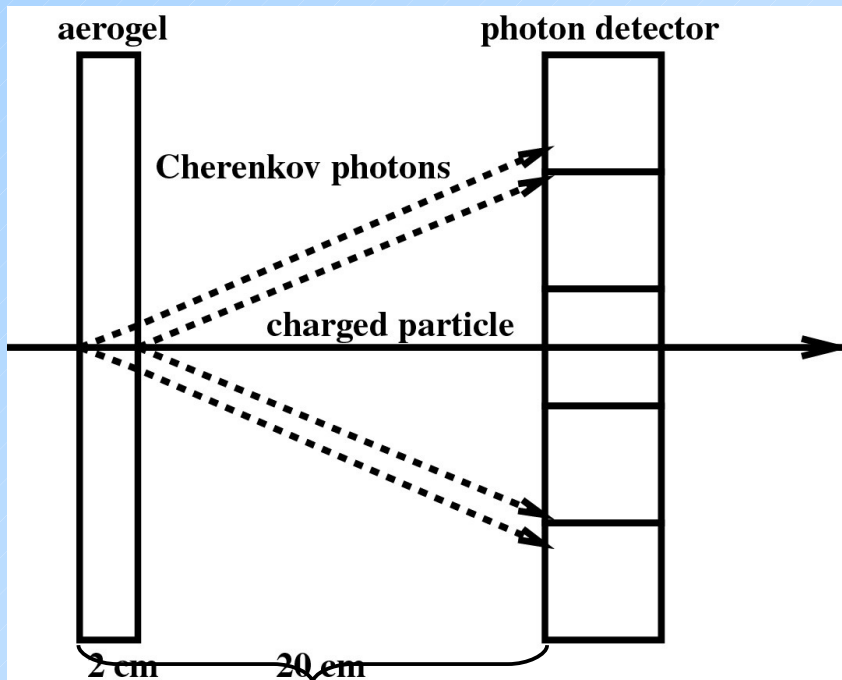

- $n \sim 1.05$ (focusing configuration)
- $\vartheta_c(\pi) = 308$ mrad @ 4 GeV/c
- $\vartheta_c(\pi) - \vartheta_c(K) = 23$ mrad @ 4 GeV/c
- pion threshold 0.44 GeV/c, kaon threshold 1.54 GeV/c
- distance from aerogel entrance window to photon detector 200 mm
- time-of-flight difference (2m from IP):
 $t(\pi) - t(K) = 180(45)$ ps @ 2(4) GeV/c

Beam test with flat-panel PMT array

2cm+2cm focusing aerogel:

- $N_{\text{ph.}} \sim 10$
- $\sigma_{\text{single}} = 14 \text{ mrad}$
- $\sigma_{\text{track}} = 4.6 \text{ mrad}$

5 σ at 4GeV/c

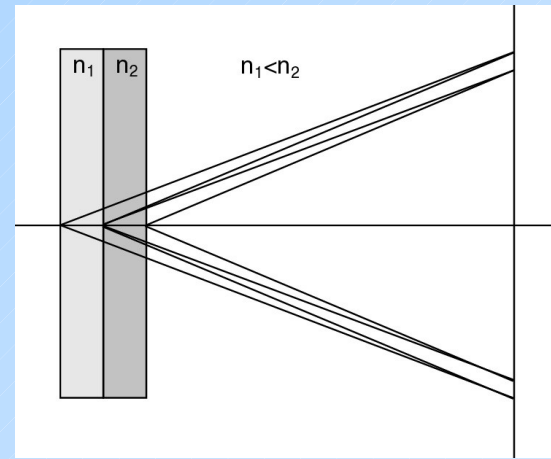
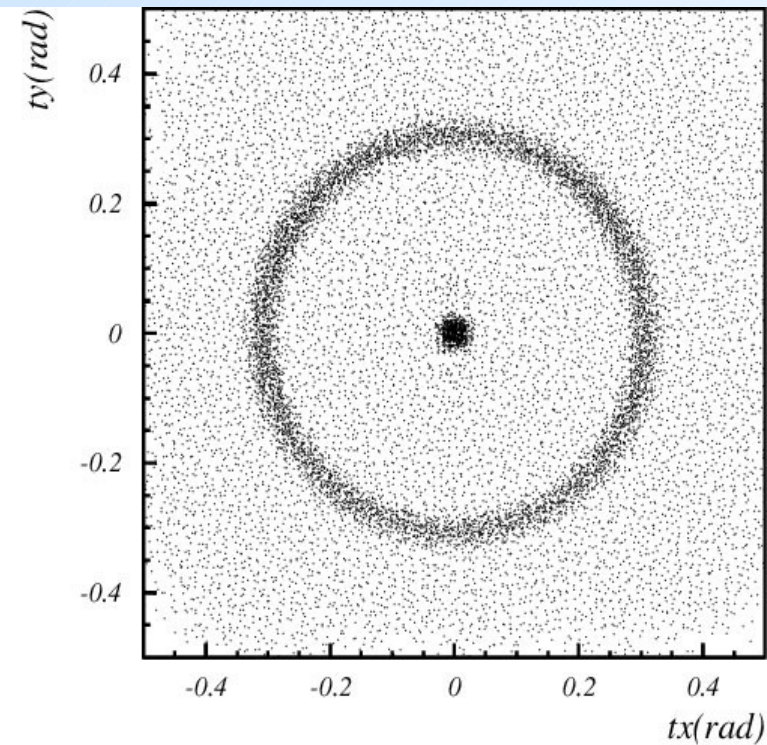
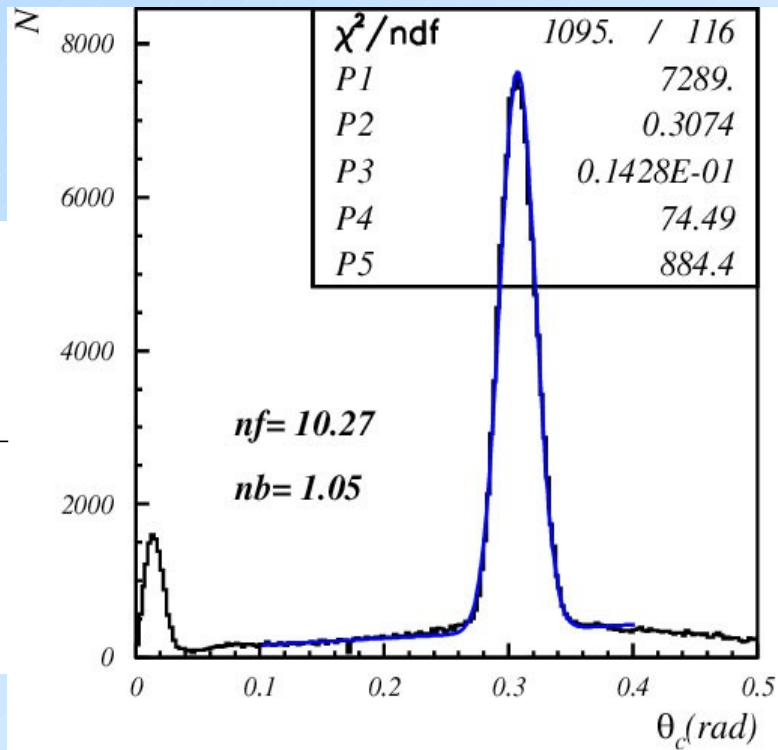
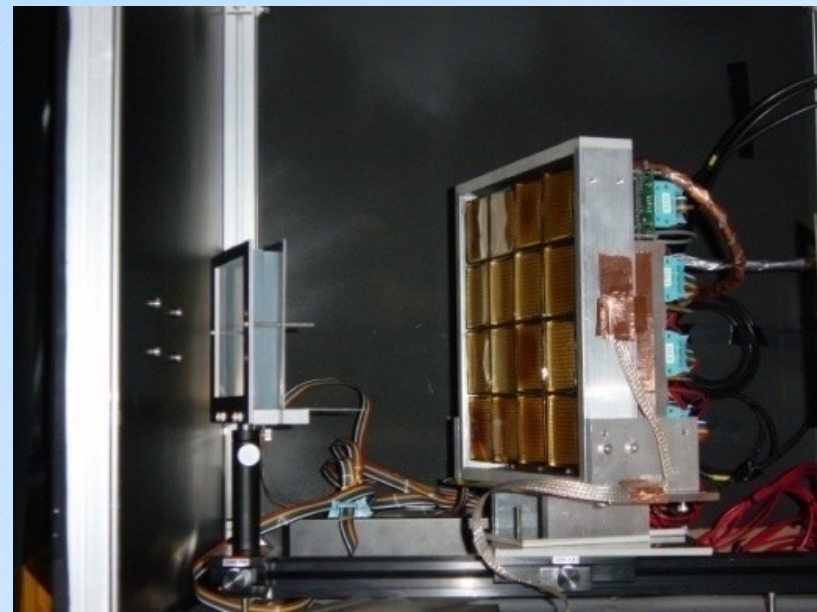

Photon detector candidate: HAPD

Hybrid avalanche photo diode - proximity focusing configuration:

- 12x12 channels ($\sim 5 \times 5 \text{ mm}^2$)
- size $\sim 74 \text{ mm} \times 74 \text{ mm}$
- $\sim 65\%$ effective area
- total gain $\sim 10^4 - 10^5$
- detector capacity $\sim 80 \text{ pF}$
- peak QE $\sim 25\%$
- works in mag. field perpendicular to the entrance window

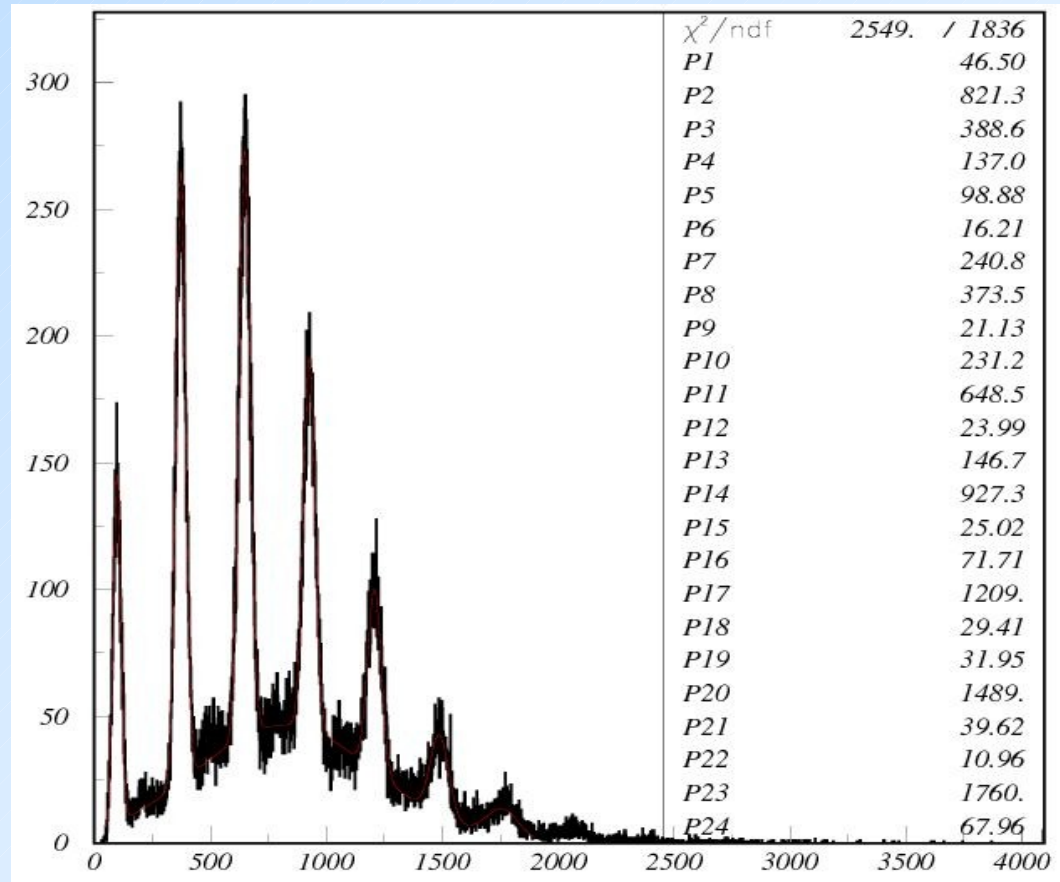
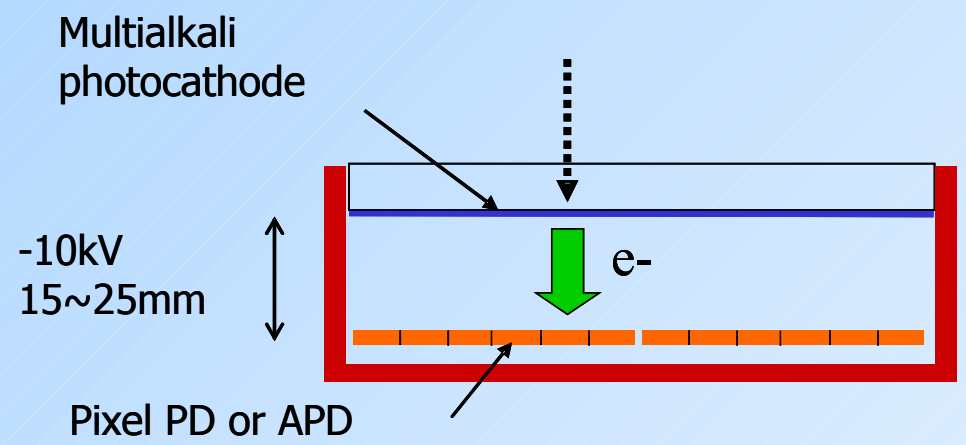
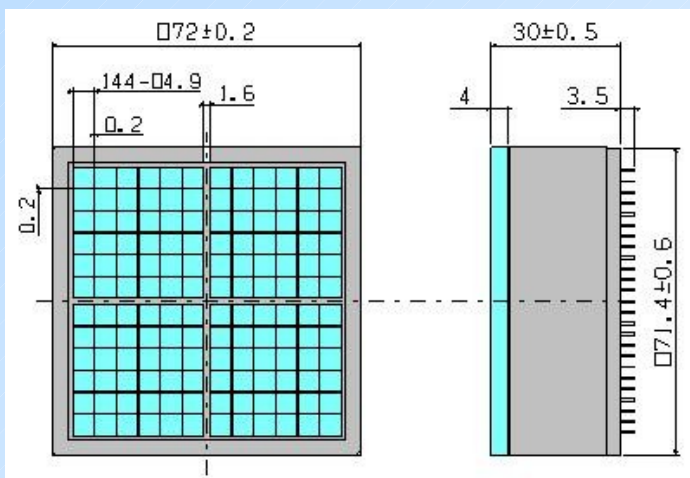
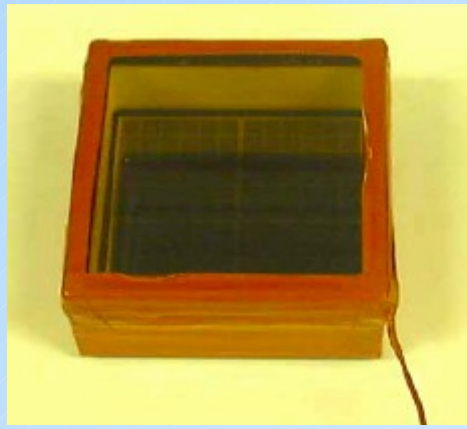

Photon detector candidate: MCP-PMT

BURLE 85011-501 MCP-PMT:

- multi-anode PMT with two MCP steps
- 25 μm pores
- bialkali photocathode
- gain $\sim 0.6 \times 10^6$
- collection efficiency $\sim 60\%$
- box dimensions $\sim 71\text{mm}$ square
- 64(8x8) anode pads
- pitch $\sim 6.45\text{mm}$, gap $\sim 0.5\text{mm}$
- effective area $\sim 52\%$
- excellent timing - $\sim 50\text{ps}$ for single ph.

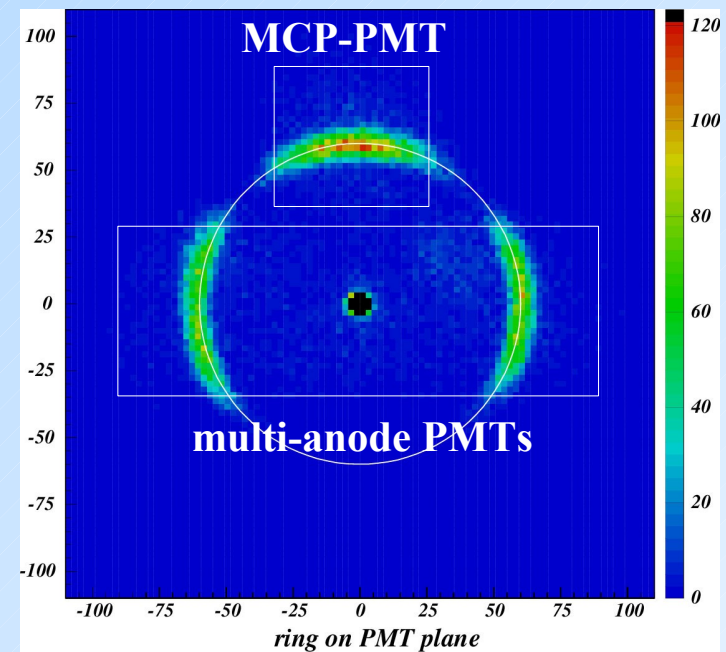
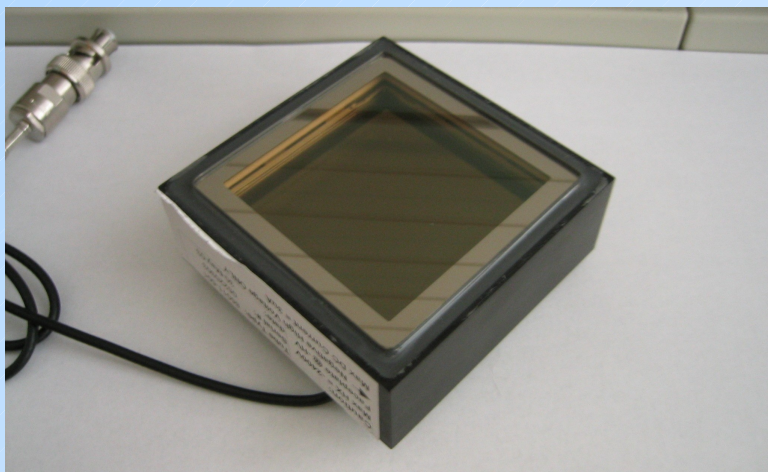

- Tested in combination with multi-anode PMTs

- $\sigma_{\vartheta} \sim 13 \text{ mrad}$ (single cluster)
- number of clusters per track $N \sim 4.5$
- $\sigma_{\vartheta} \sim 6 \text{ mrad}$ (per track)
- $\rightarrow \sim 4 \sigma \pi/K$ separation at 4 GeV/c

- 10 μm pores required for 1.5T
- use new package with improved effective area
- aging study should be done

Additional feature: RICH+TOF

Make use of fast photon detectors: measure time-of-flight with Cherenkov photons from **PMT window** and **aerogel**

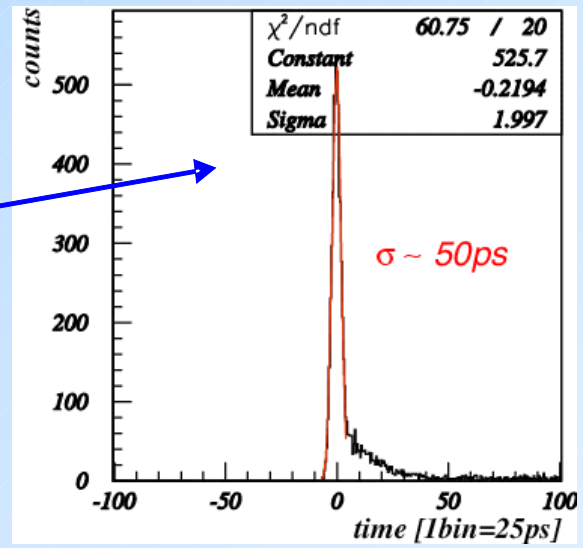
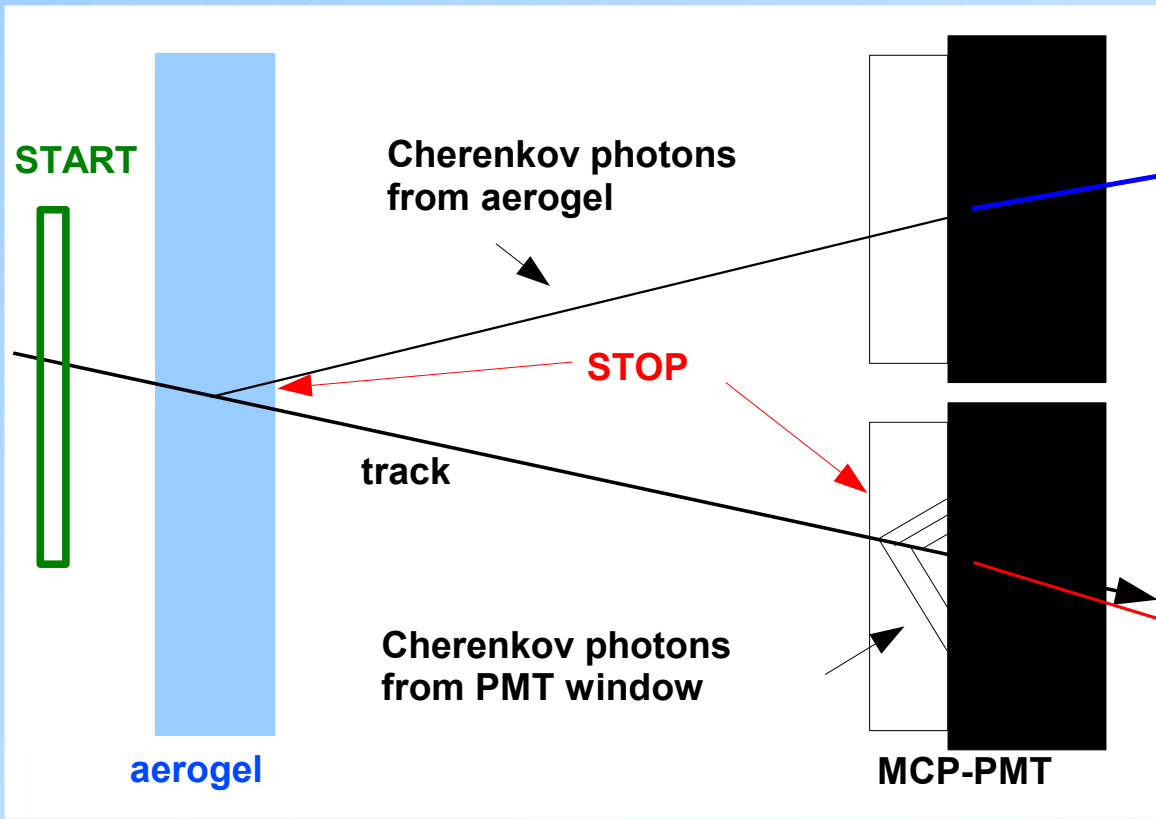

Beam test:

- 50ps per single photon (~20ps per track)

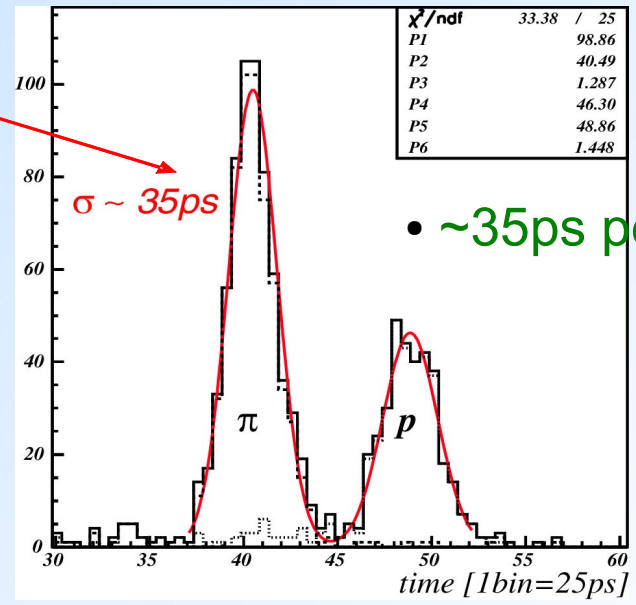

• ~35ps per track

- Cherenkov photons from the window can be used to positively identify particles below the threshold in aerogel

Light guide simulation

Simulation includes:

- refraction at LG entrance
- total reflection
- gap between LG exit and SiPM surface

Not included:

- absorption
- imperfect surface

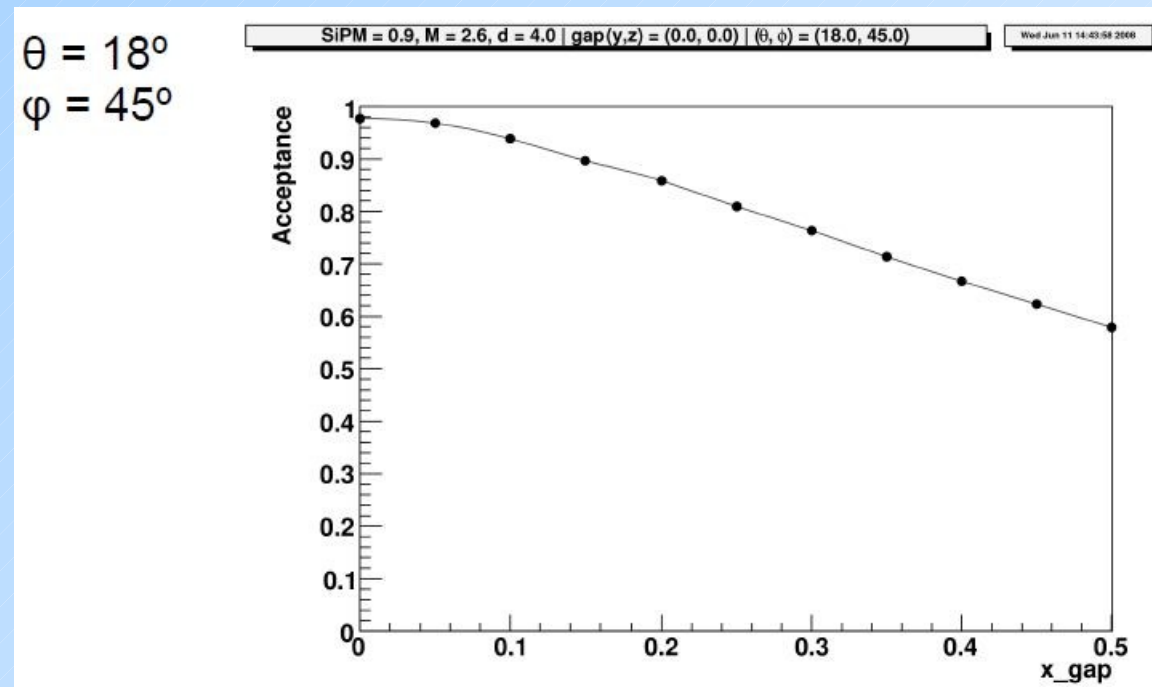
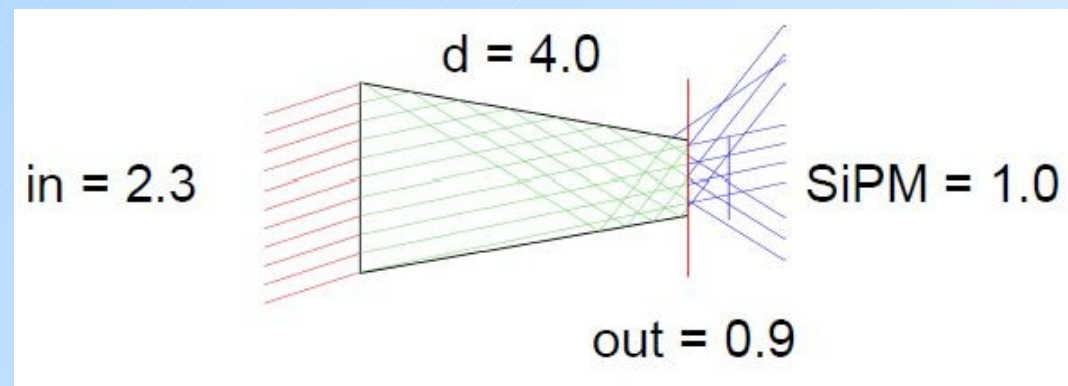

t=18,p=45

gap	w	w/o	A	
0.00	97.67	19.03	5.13	
0.05	96.62	19.09	5.06	
0.10	94.11	18.98	4.96	
0.15	89.68	18.77	4.78	
0.20	85.99	18.87	4.56	
0.25	81.06	18.99	4.27	
0.30	76.12	19.1	3.99	
0.35	71.49	18.95	3.77	
0.40	66.85	19	3.52	
0.45	62.44	18.98	3.29	
0.50	58.39	19	3.07	

Beam area T4-H6-B @ CERN

- +120 GeV/c pions
- spills every 42s for ~5s
- beam size ~1cm²

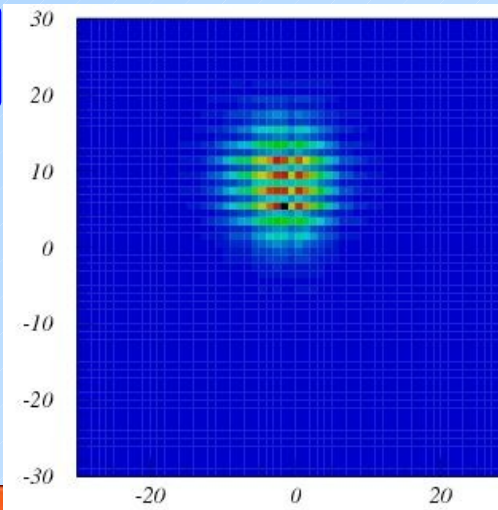

track (x,y) at T1

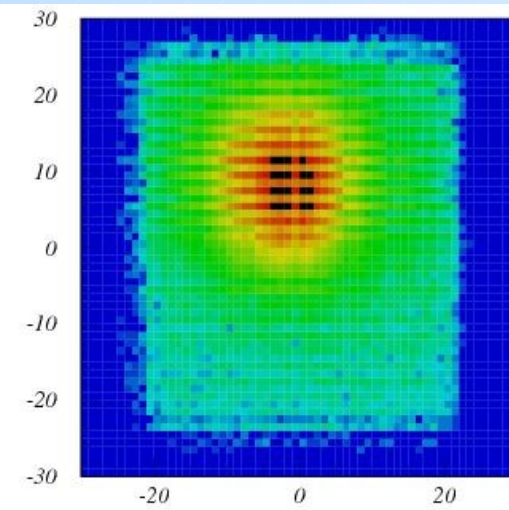

track (x,y) at T1

- beam profile (scale in mm)



Beam area T4-H6-B

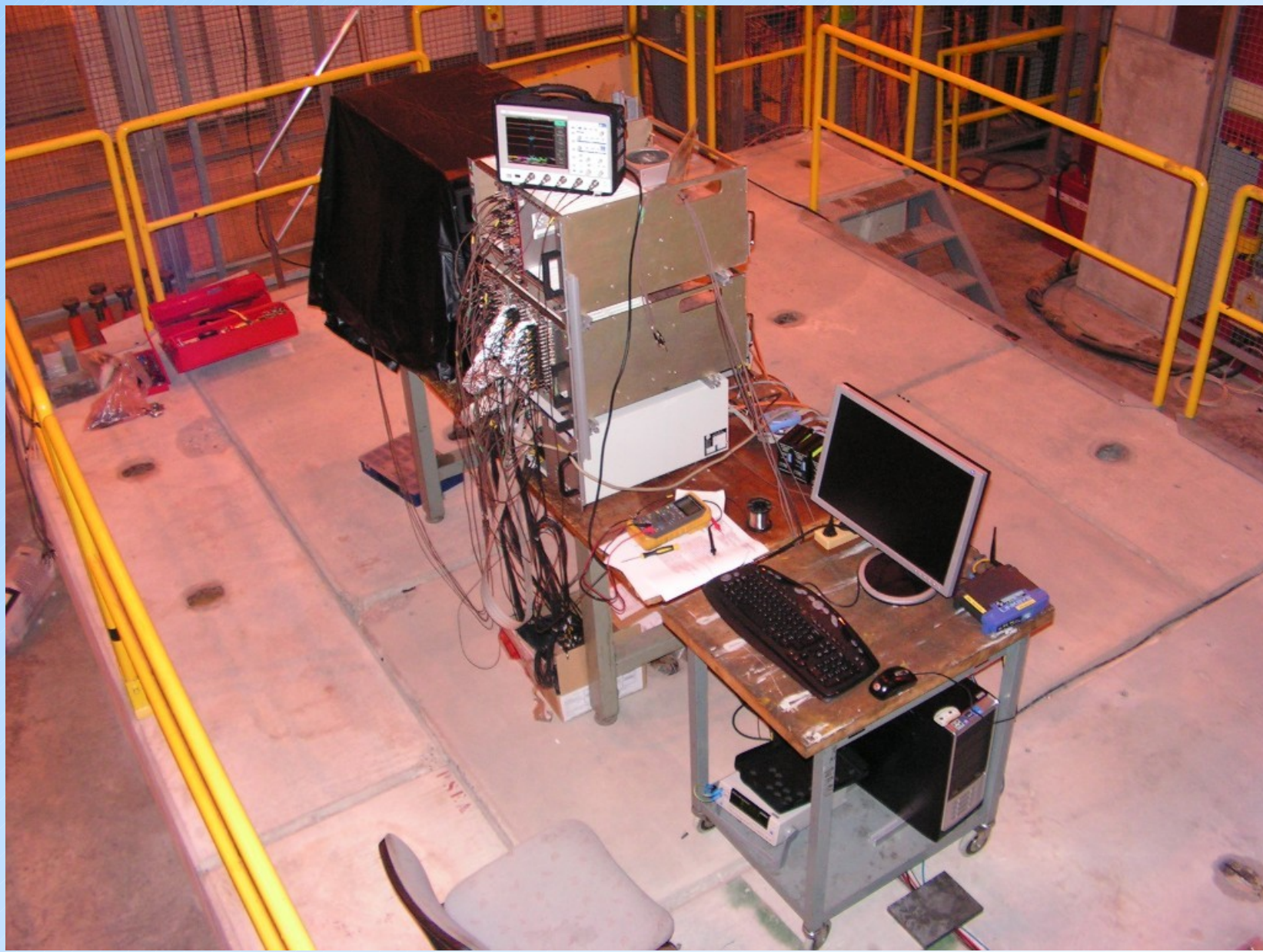

Cherenkov angle distributions

w/o light guides

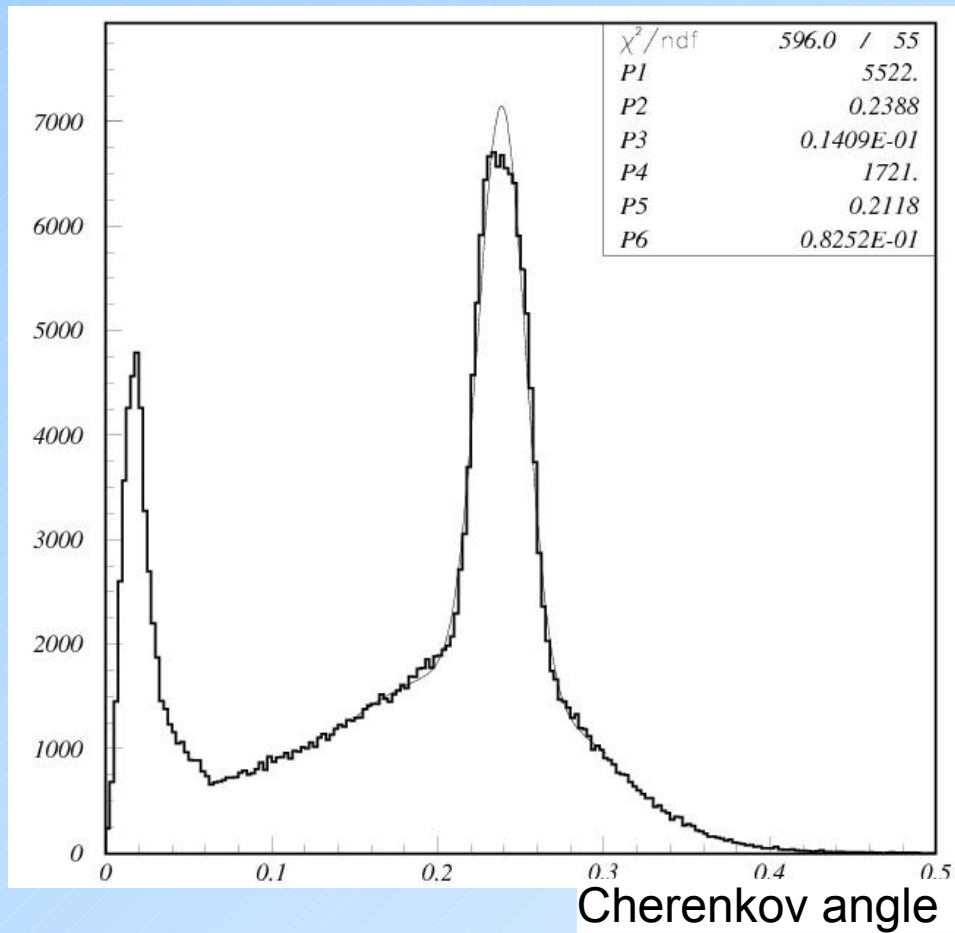

w/ light guides

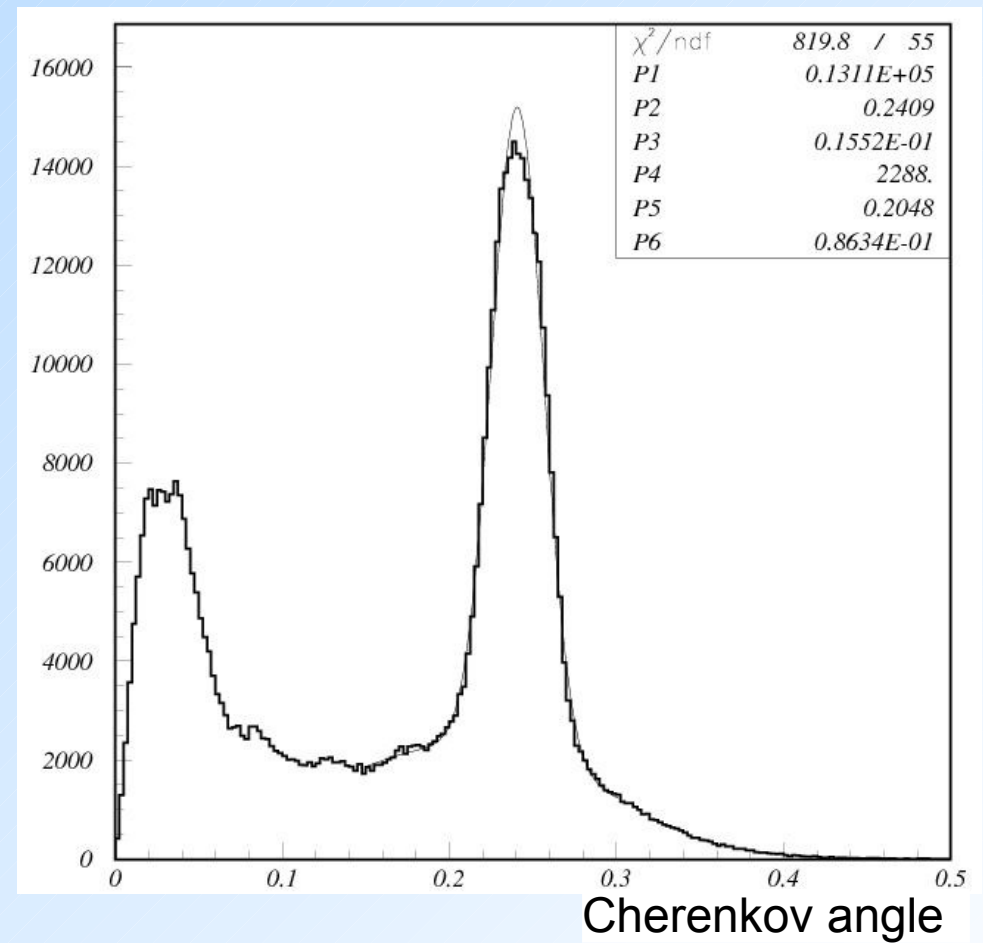

Cosmic test setup

Two configurations of 6 Hamamatsu MPPCs were used:

- (HC100, HC050, HC025)x(metal, ceramic)
- 6 x HC100, metal

All six MPPCs were connected to same supply line using additional dividers:

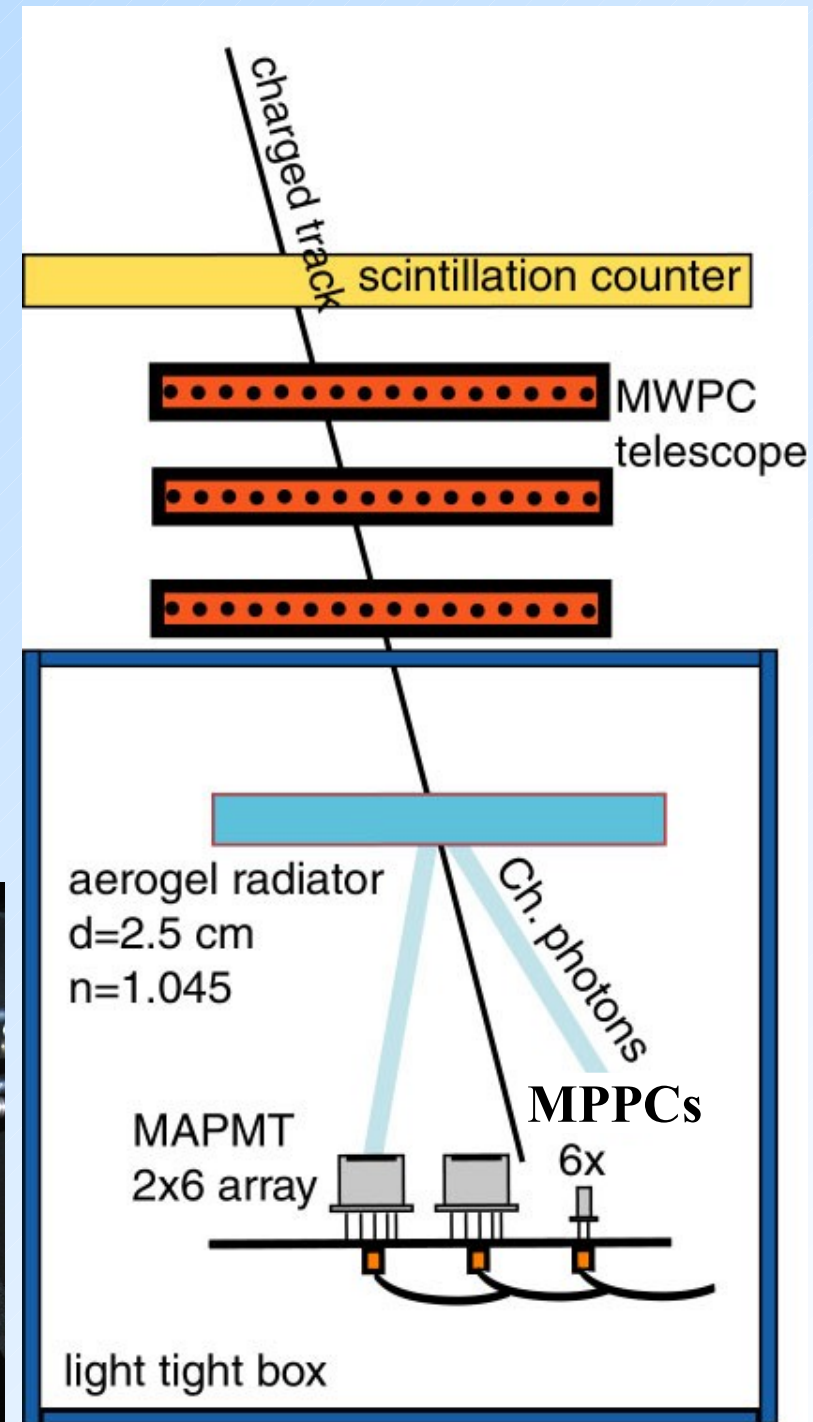
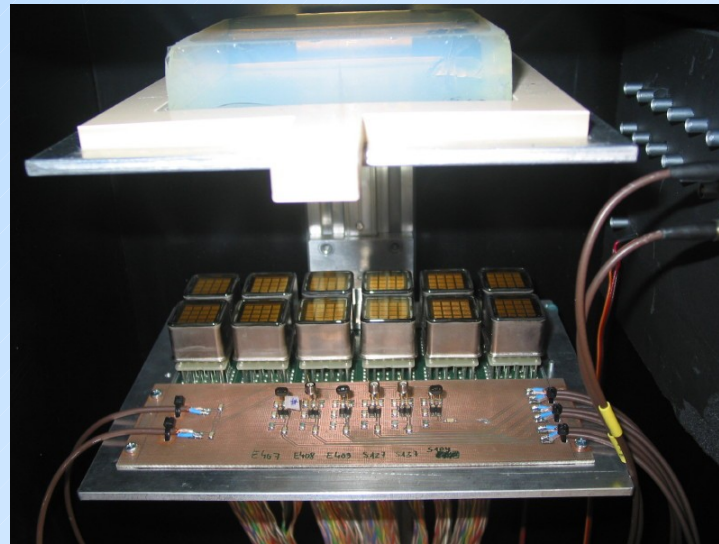
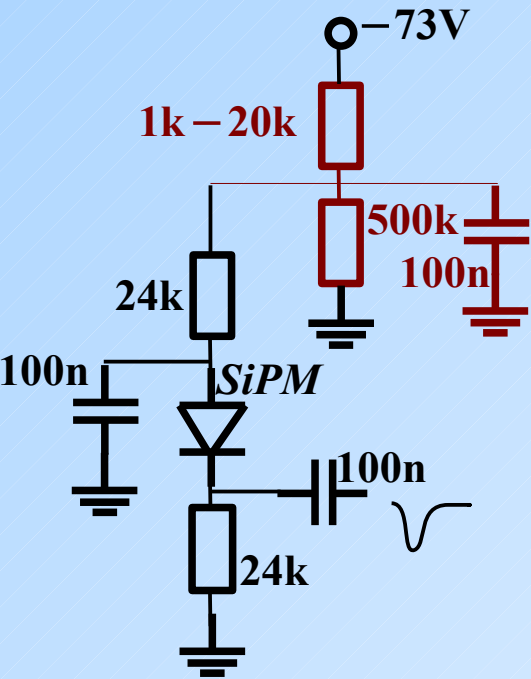

SiPM: number of photons

- 43600 tracks
- Cherenkov photons ~ 146
- ~ 0.0033 photons per track
- area ~ 6 mm²

Compare with PMTs:

- Cherenkov photons ~ 22000
- active area ~ 3900 mm²

$$N_{SiPM} / N_{PMT} \times S_{PMT} / S_{SiPM} \sim 4.2$$

→ Per photon detector area
SiPMs give 4 x more photons.

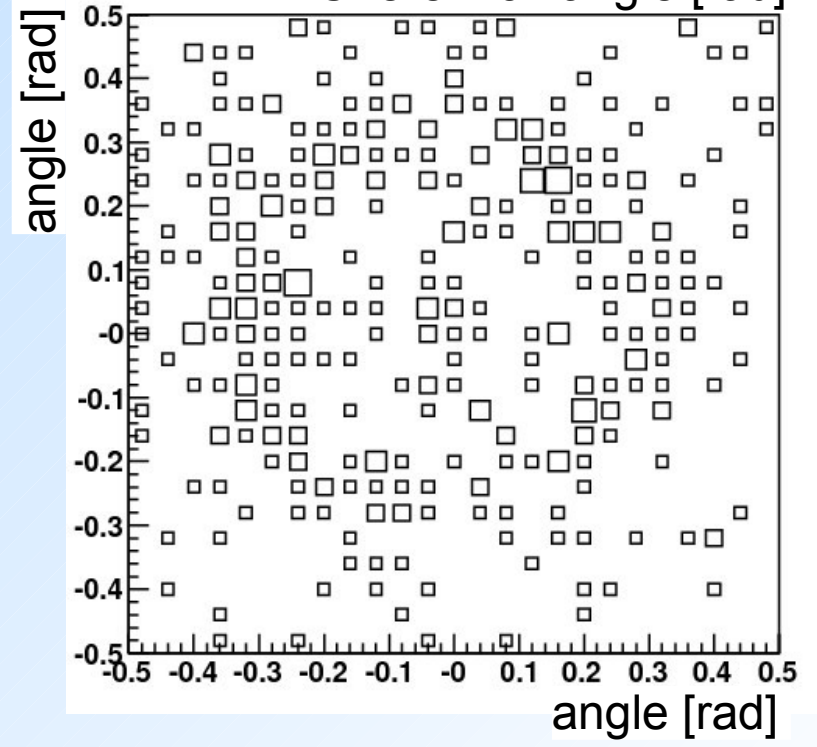
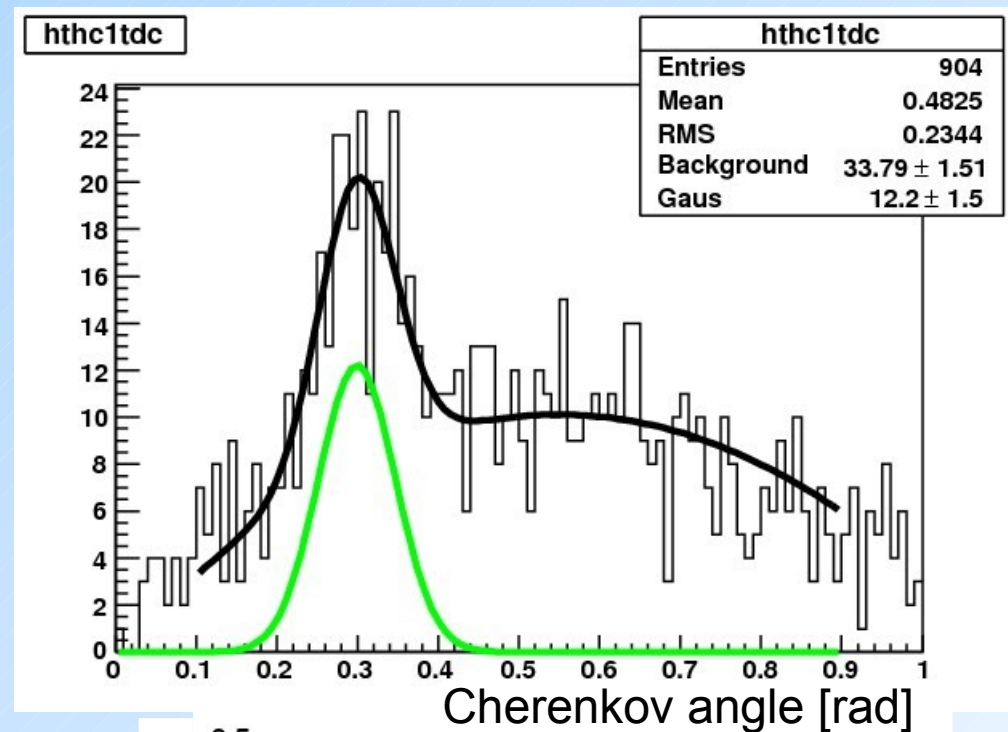

Cherenkov ph. with light guides

With light guides:

- 38100 tracks
- Cherenkov photons ~ 285
- 0.0072 photons per track

No light guides:

- 43600 tracks
- Cherenkov photons ~ 146
- 0.0033 photons per track

$$N_{wl} / N_{w/o} \sim 2.2$$

~1mm gap

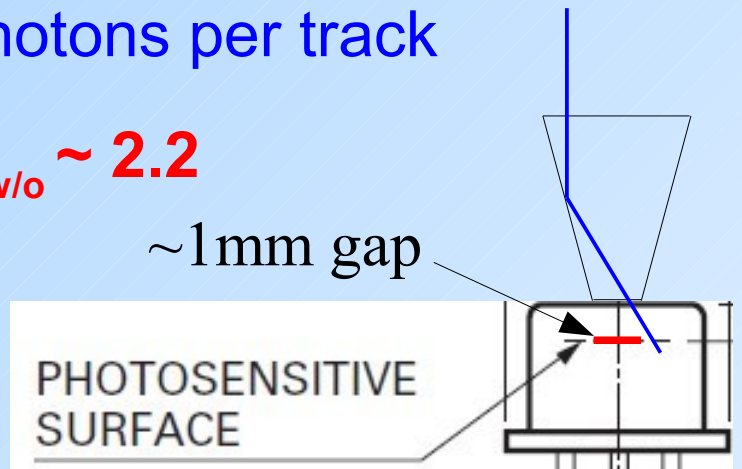

Light guide should be as close as possible to the SiPM surface (now: epoxy layer)

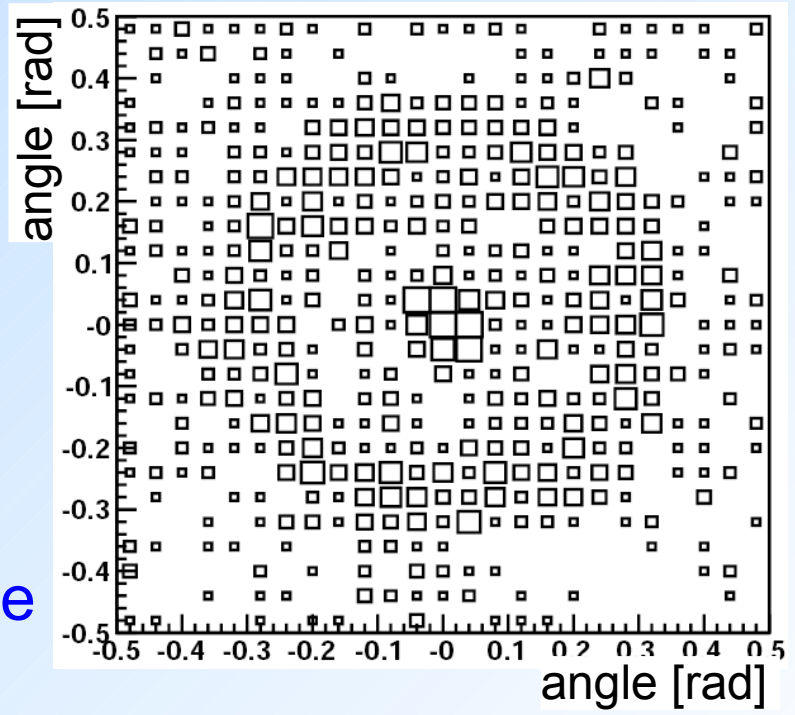
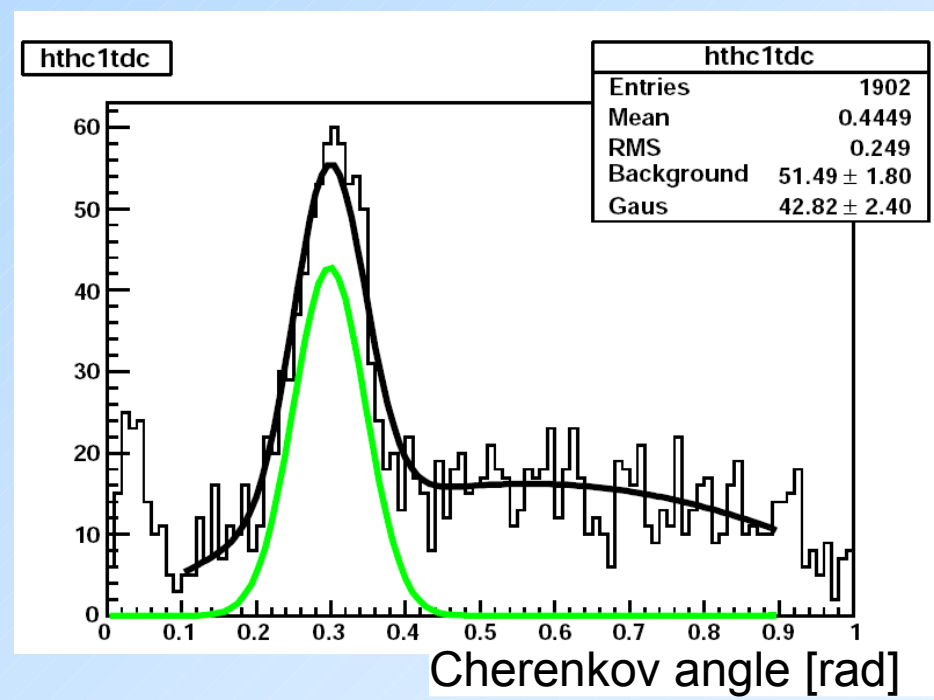

Light guide 3.5x3.5mm² to 1x1mm²

First attempt to attach light guides to SiPMs.

- area ratio ~ 12
- average efficiency ~ 0.5 (entrance to exit surface)
- light guide test with pencil beam (400nm, 90°)

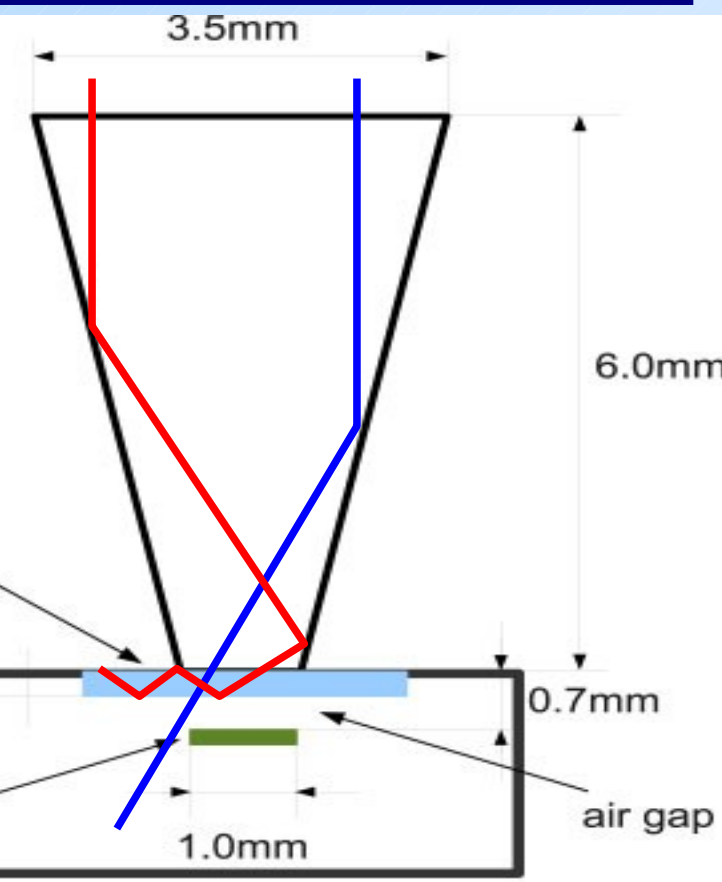
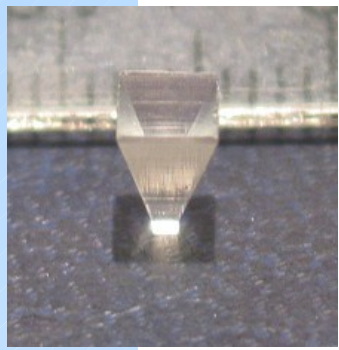

PMT

SiPM

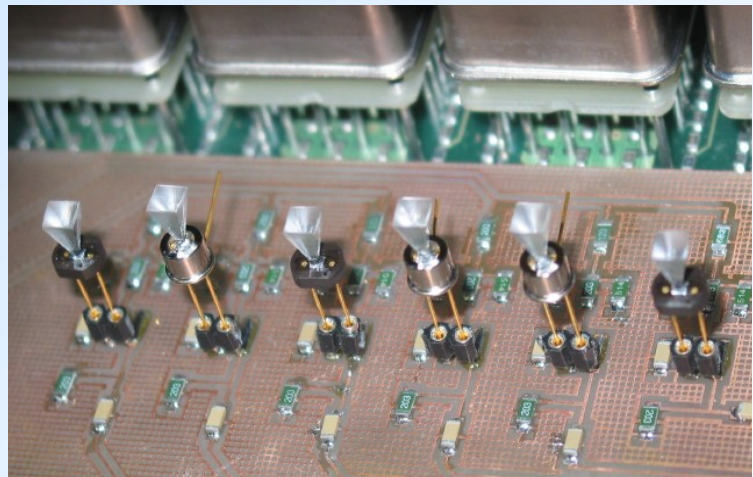
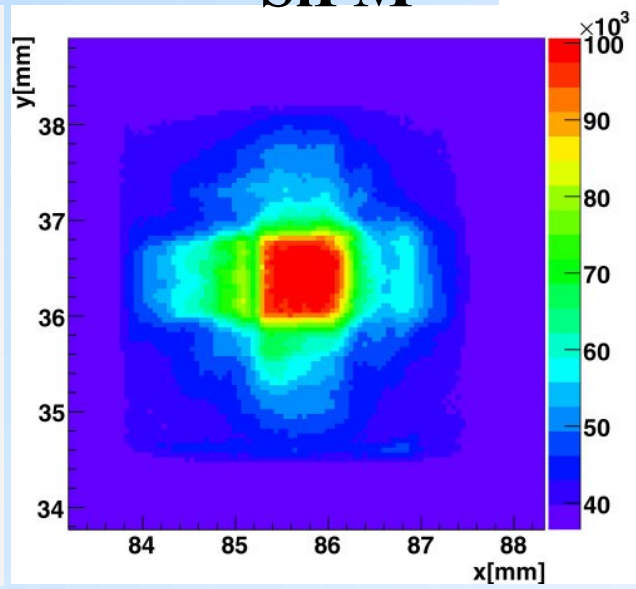
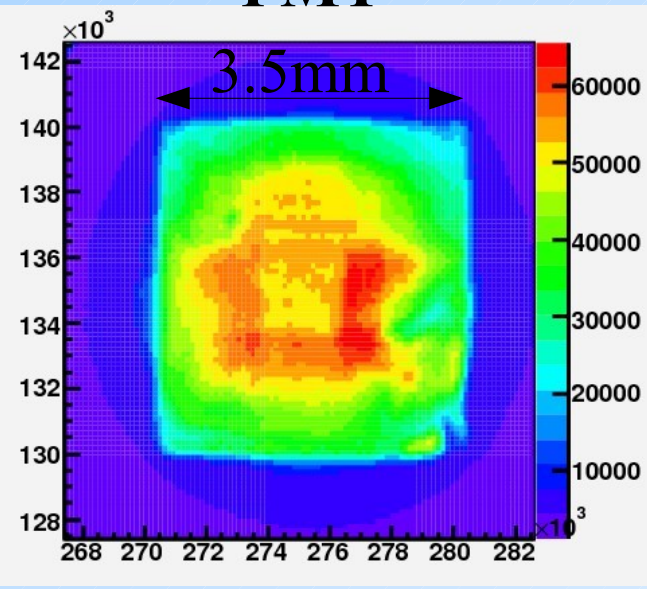

Cherenkov ph. with light guides

- Spherical light guides give better results with metal package:

$$N_{w/} / N_{w/o} \sim 3.6$$

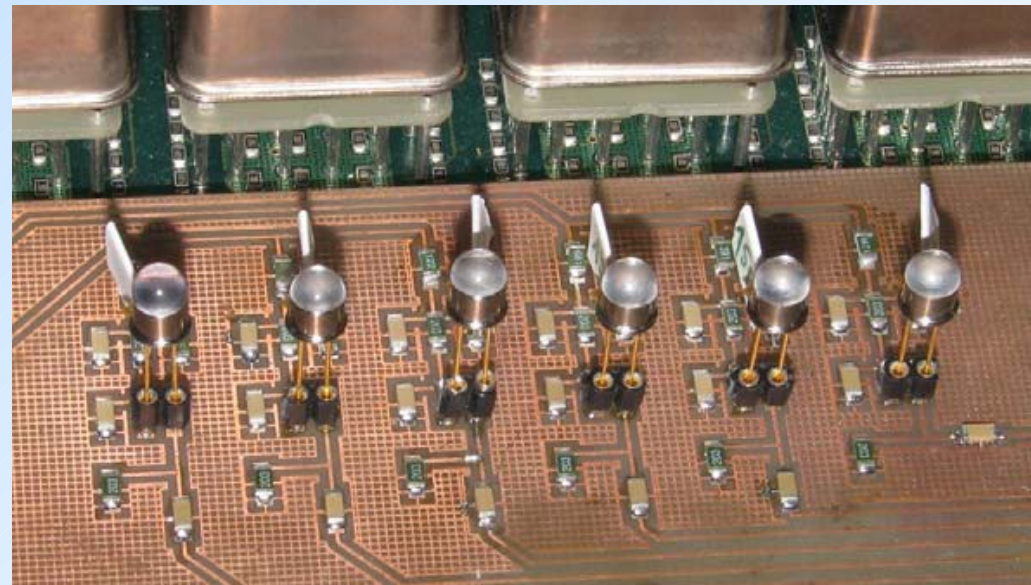
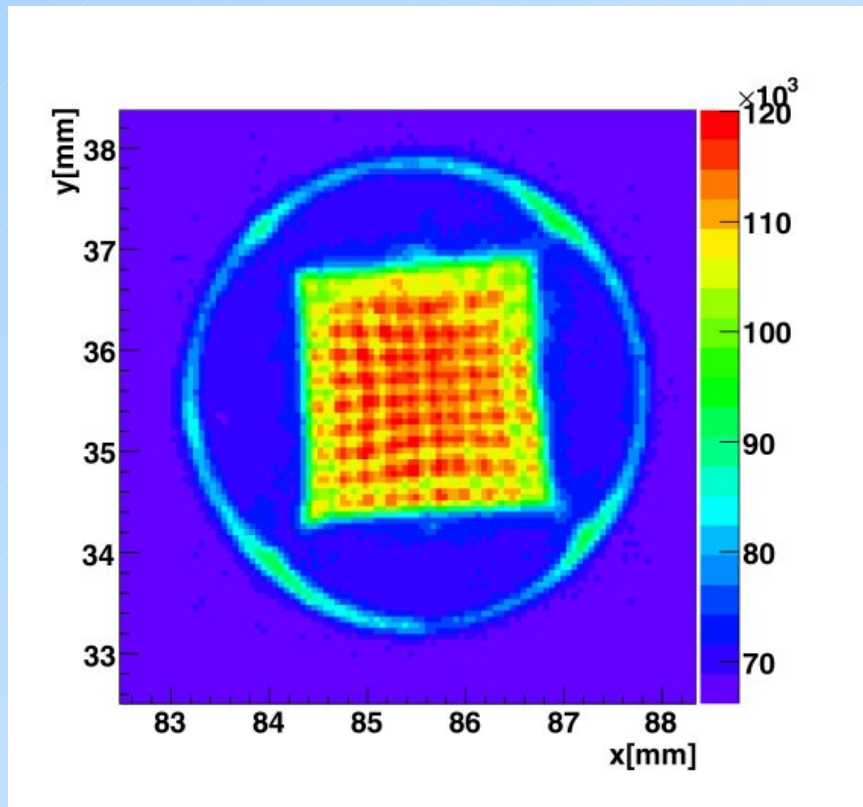
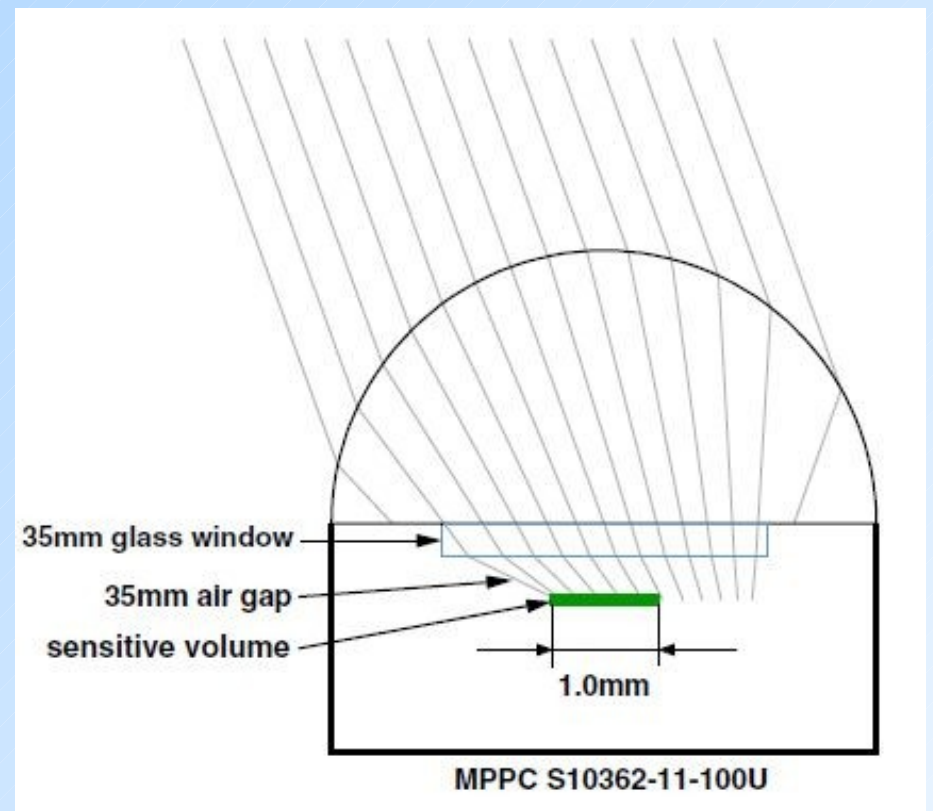

Cherenkov angle distributions for 1ns time windows

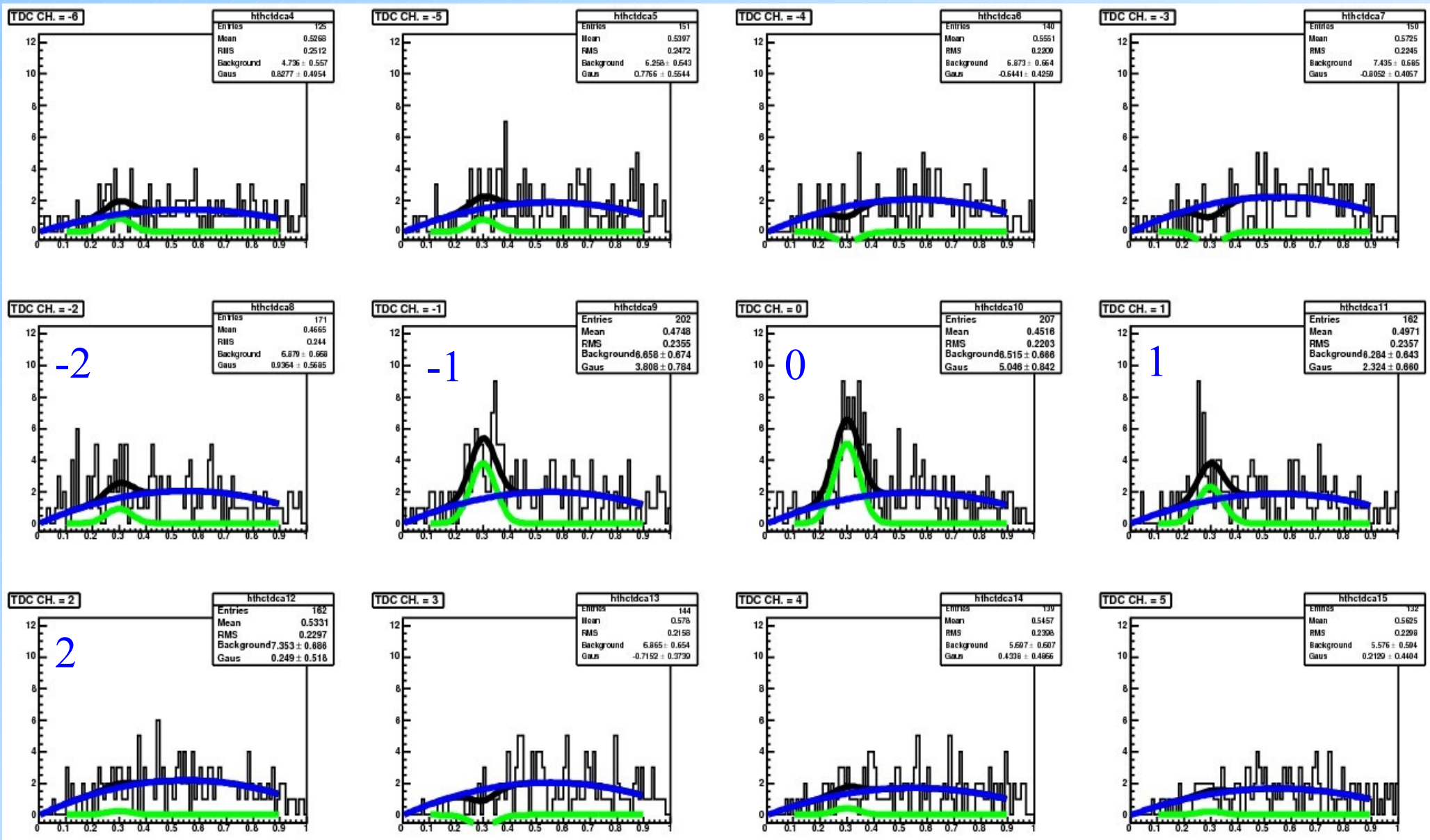

Beam test setup

- 2 MWPCs for tracking and scintillators for timing
- MPPC array w/o or w/ light guide (pad size $\sim 5.1\text{mm}$)
- Hamamatsu MCP-PMT (16 channel variant of TOP MCP-PMT, pad size $\sim 5.5\text{mm}$)
- aerogel $n=1.045$, $d=20\text{mm}$ (distance 200mm)
- (Burle 64 channel MCP-PMT - not used)

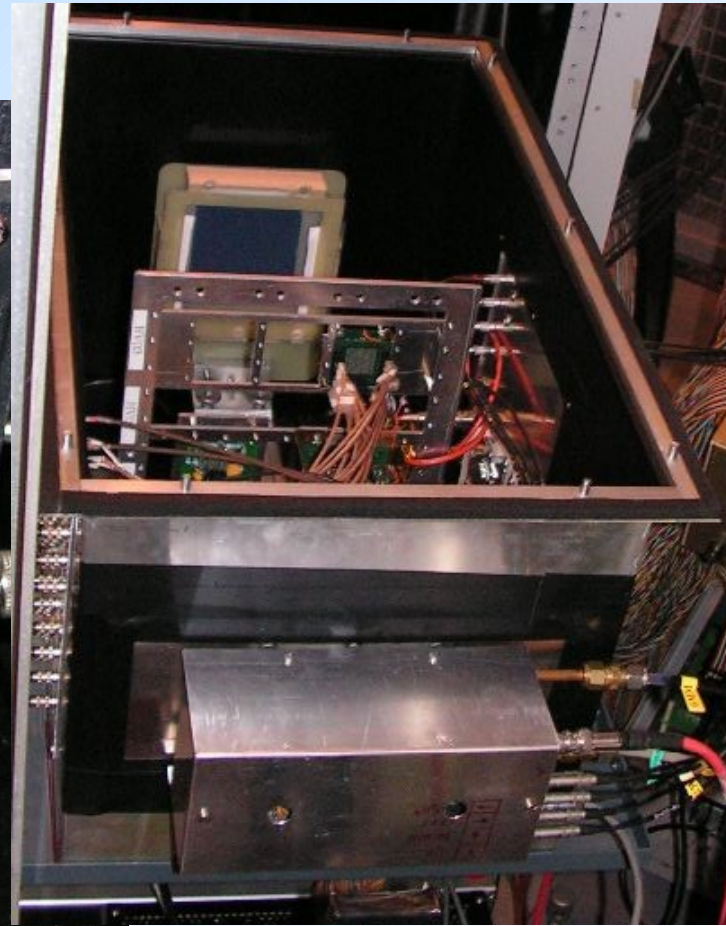
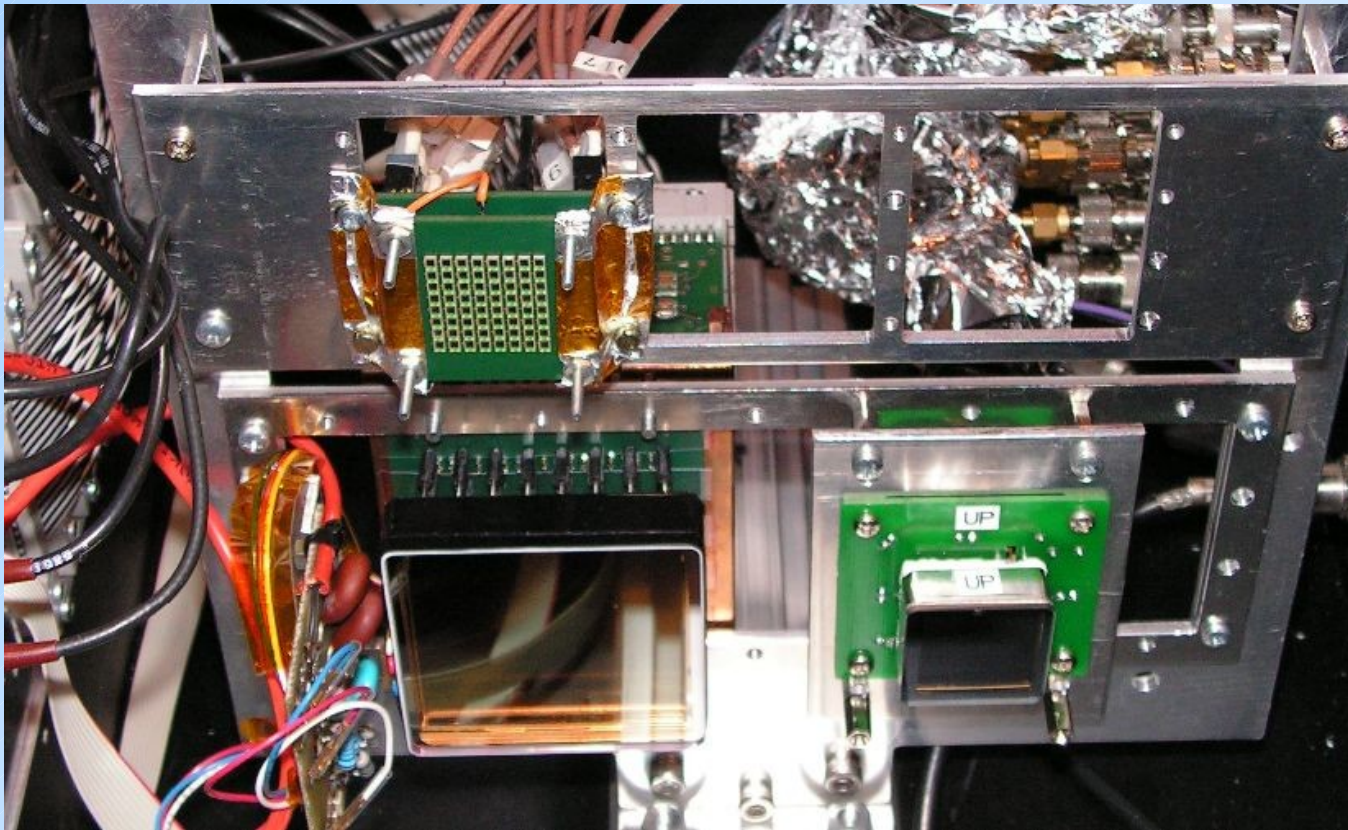

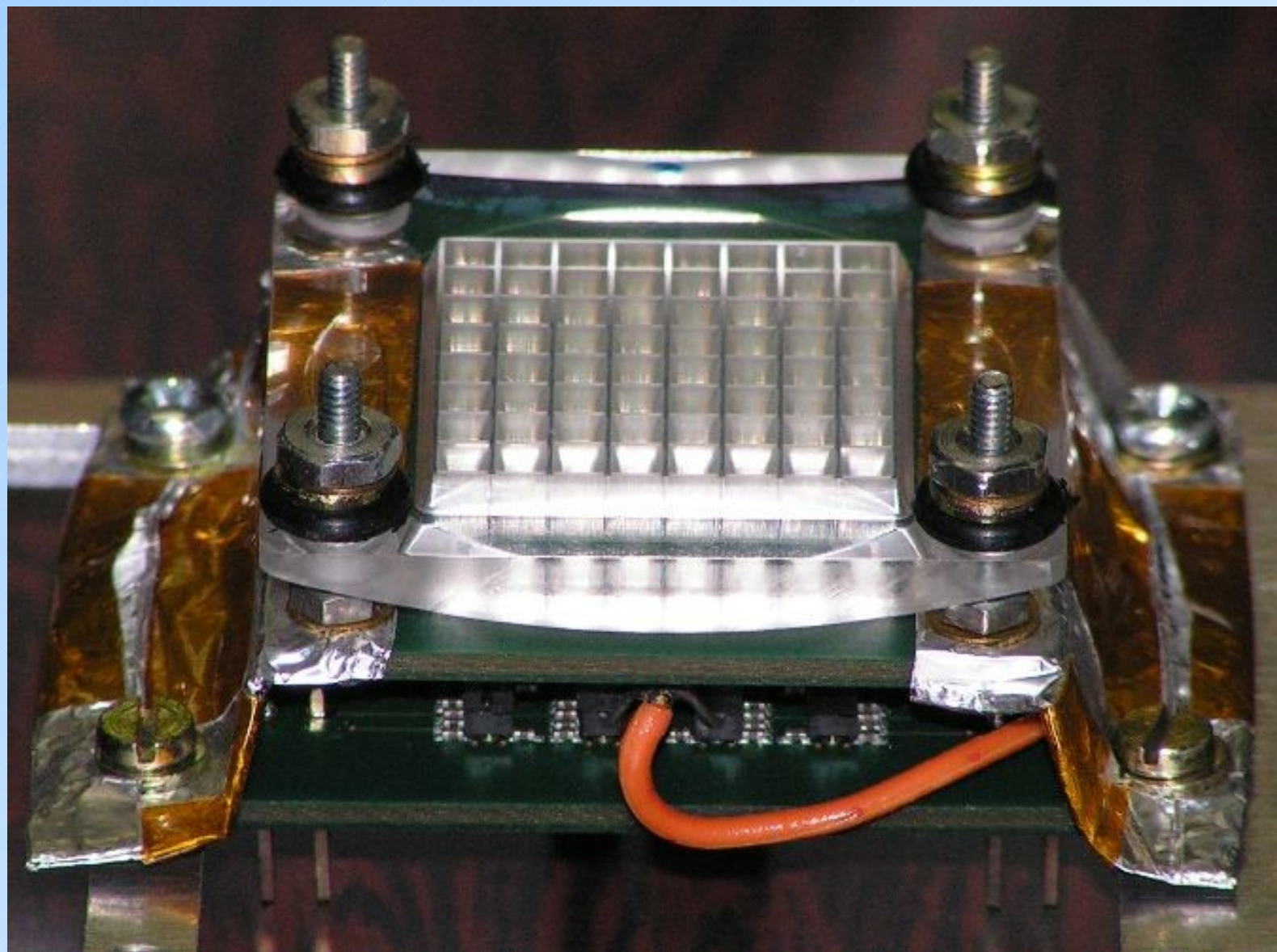

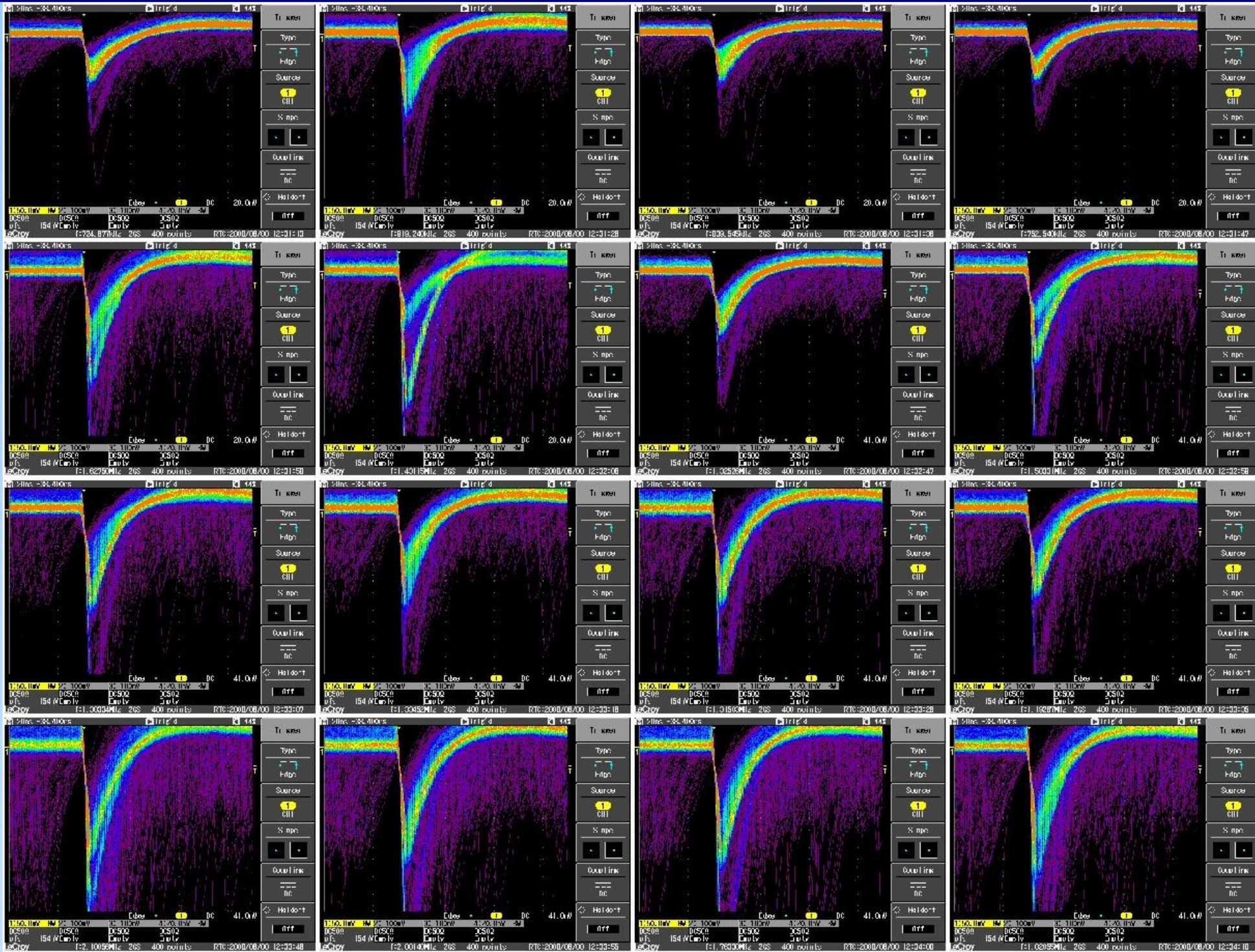

TDC distributions of MPPC hits for all events

- total noise rate $\sim 27\text{MHz}$ ($\sim 400\text{kHz/MPPC}$)
- signal to noise improves by factor ~ 2.6 with light guides

w/o light guides ($\sim 140\text{k}$ events)

w/ light guides ($\sim 70\text{k}$ events)

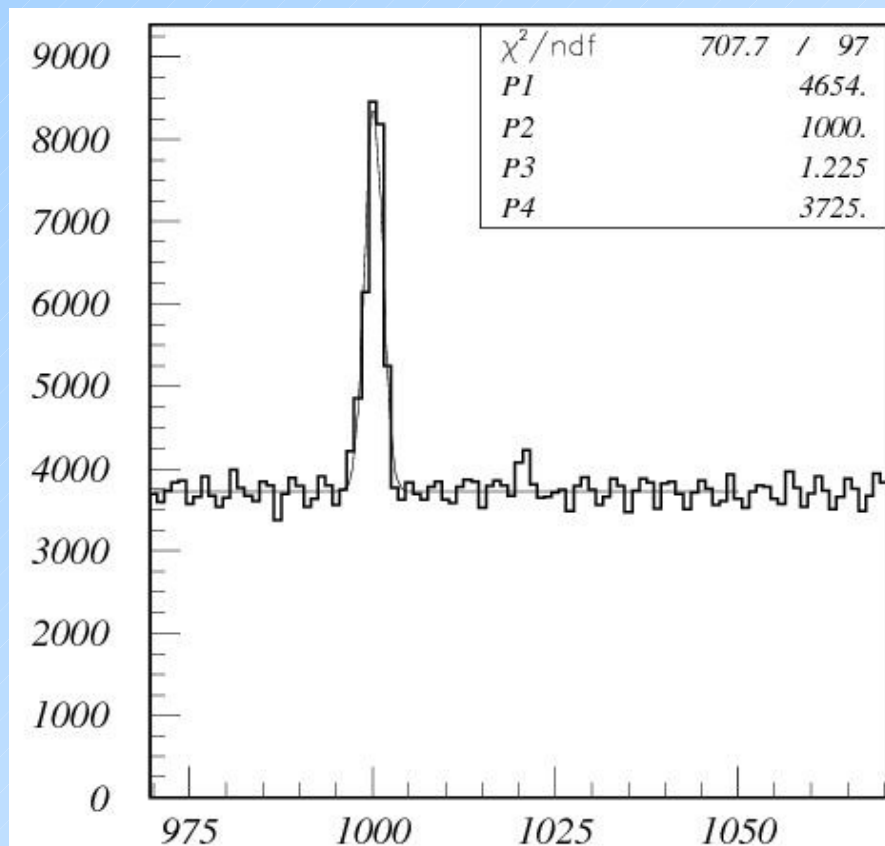

TDC of all hits

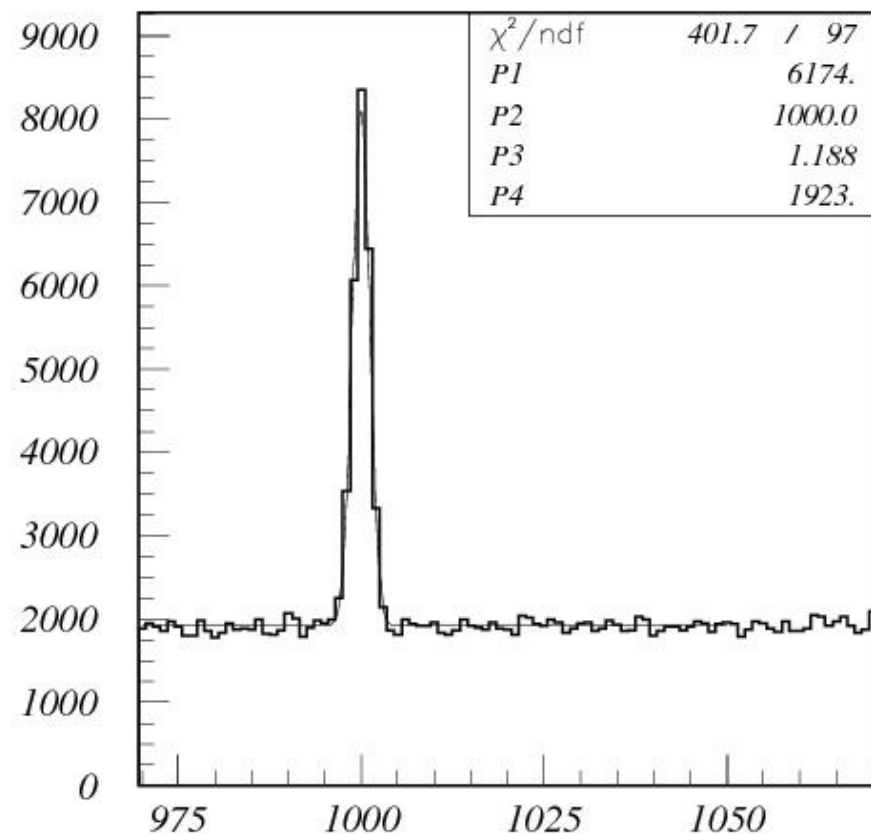

TDC of all hits

Ring images

w/o light guides (~70k events)

w/ light guides (~35k events)

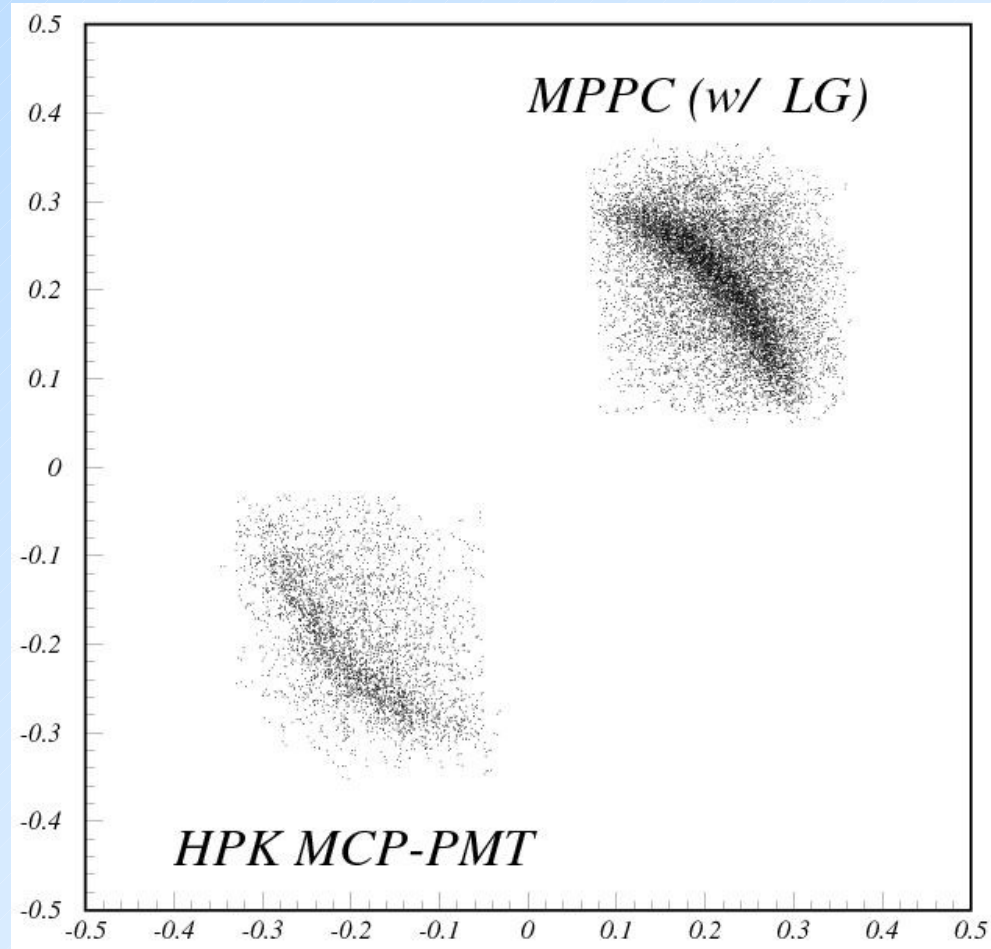
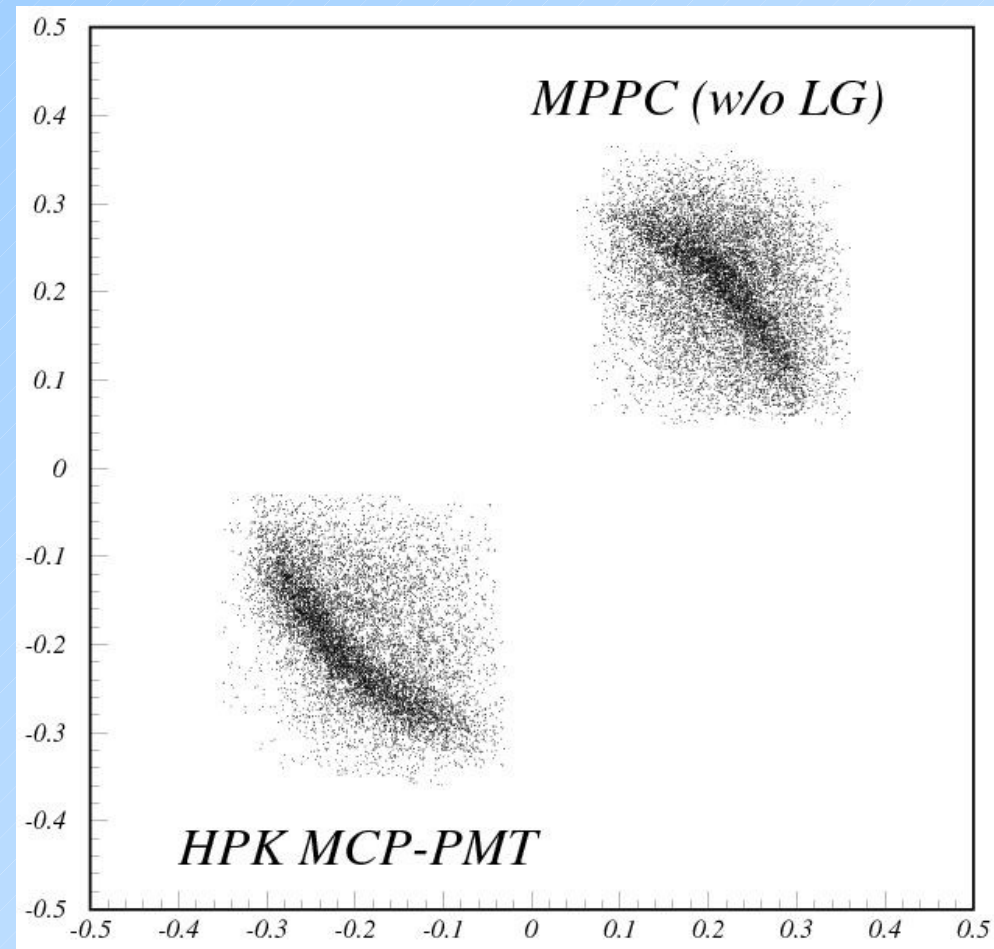

Cherenkov angle distributions - MPPCs w/o LG

- ratio of detected photons: ~ 1.1

MPPCs w/o LG

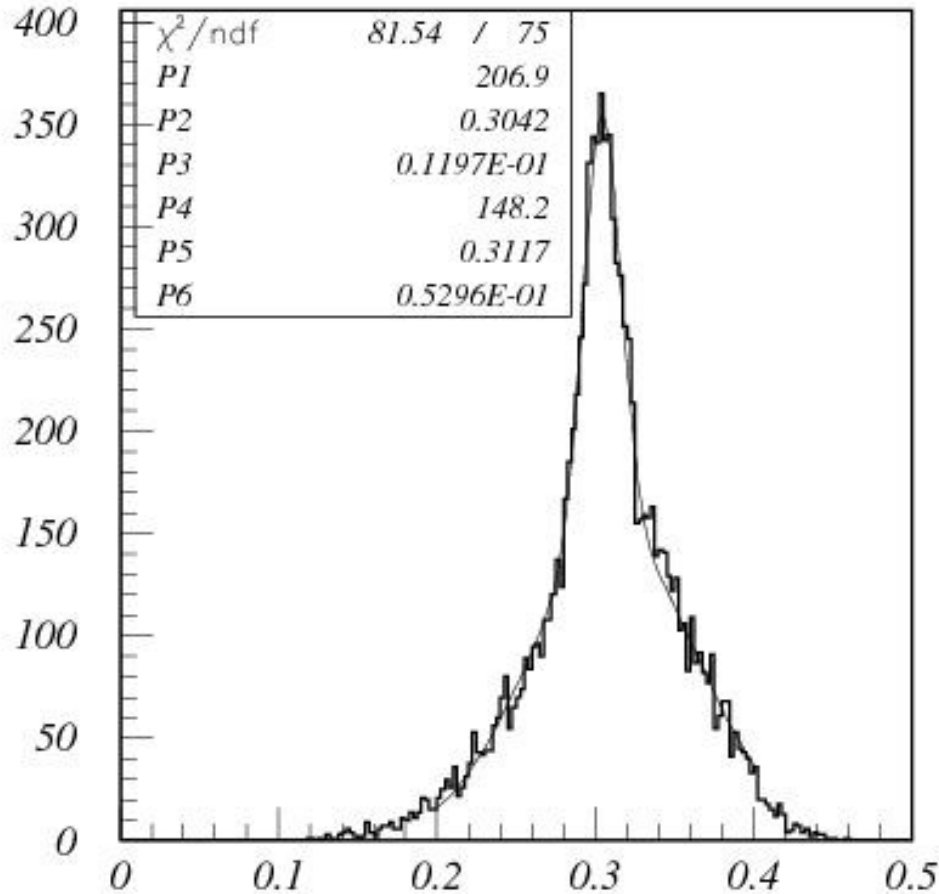

MCP-PMT

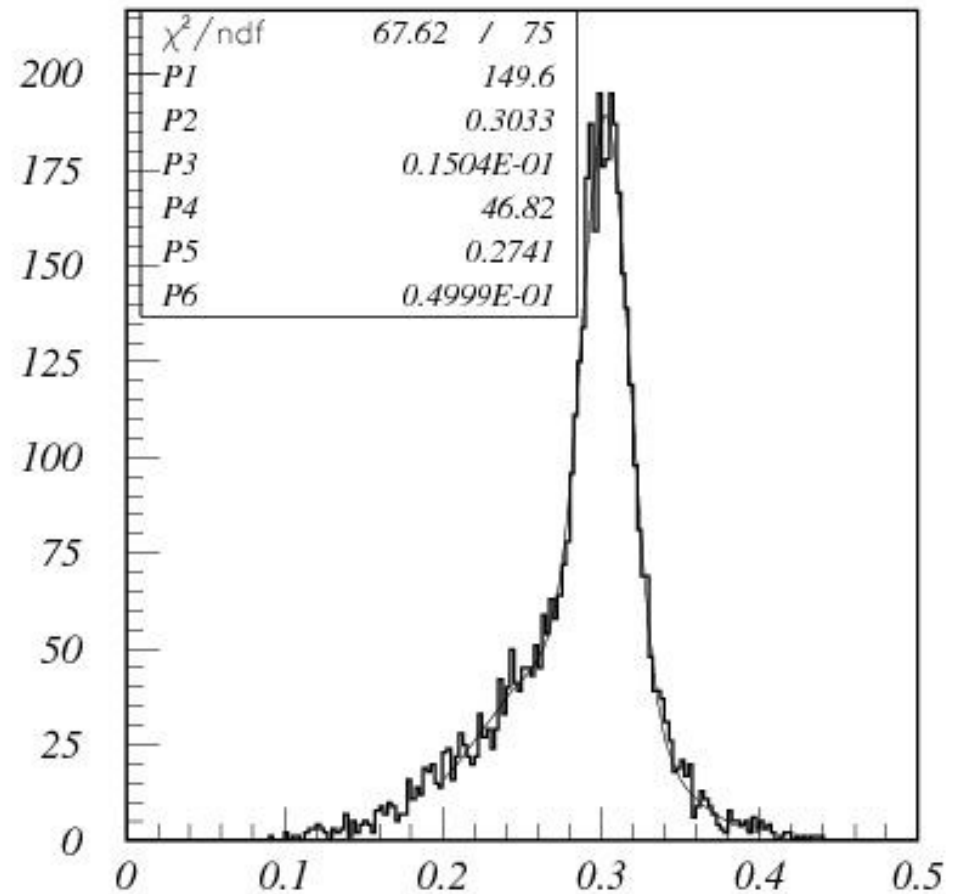

Cherenkov angle distributions - MPPCs w/ LG

- ratio of detected photons: ~ 2.5

MPPCs w/ LG

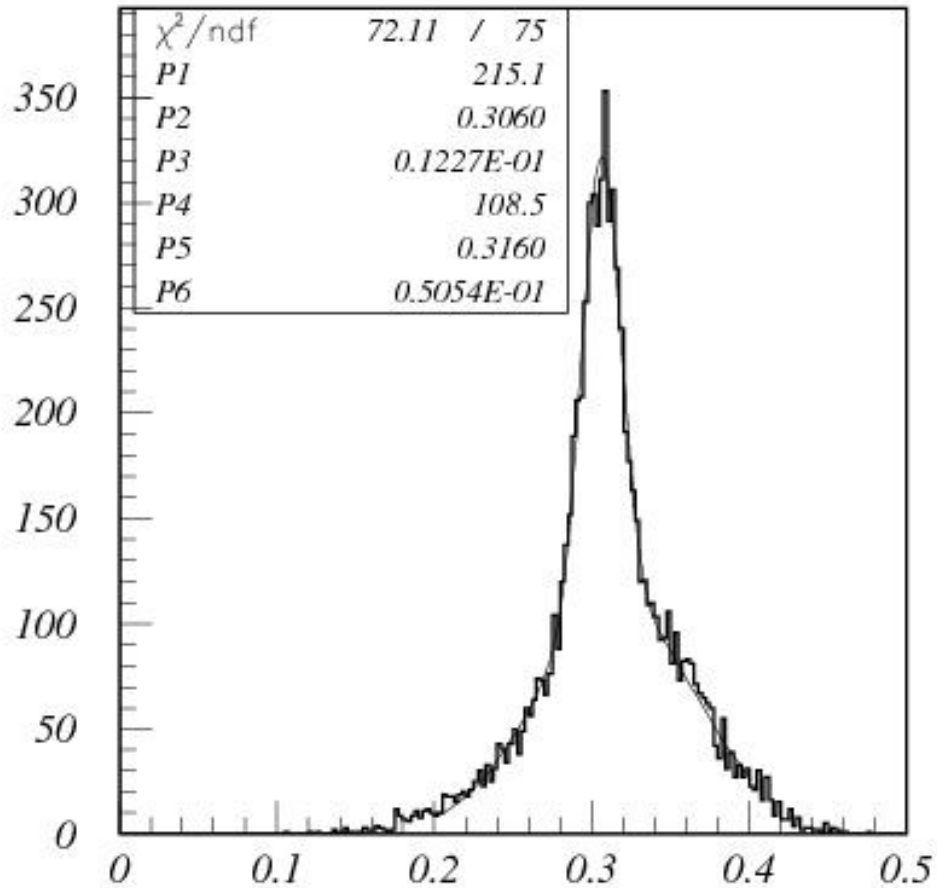

MCP-PMT

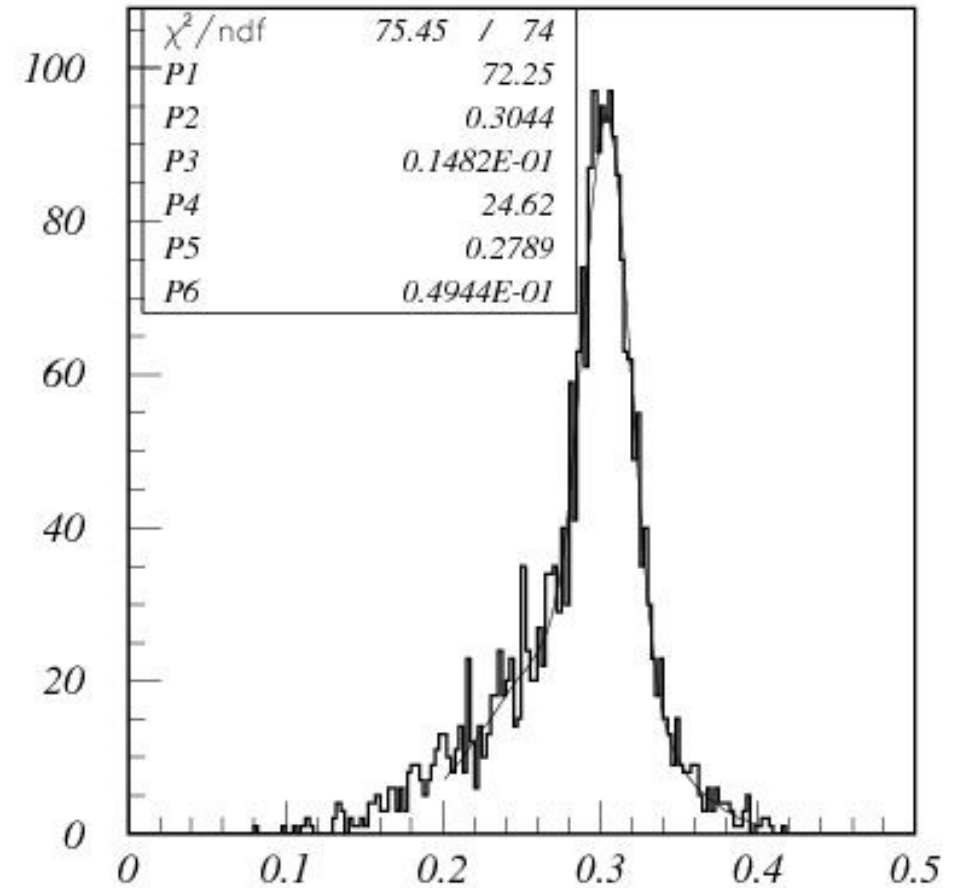

Light collection: required angular range

For our application only a limited angular range of incident light has to be covered at a given position on the detector

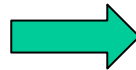
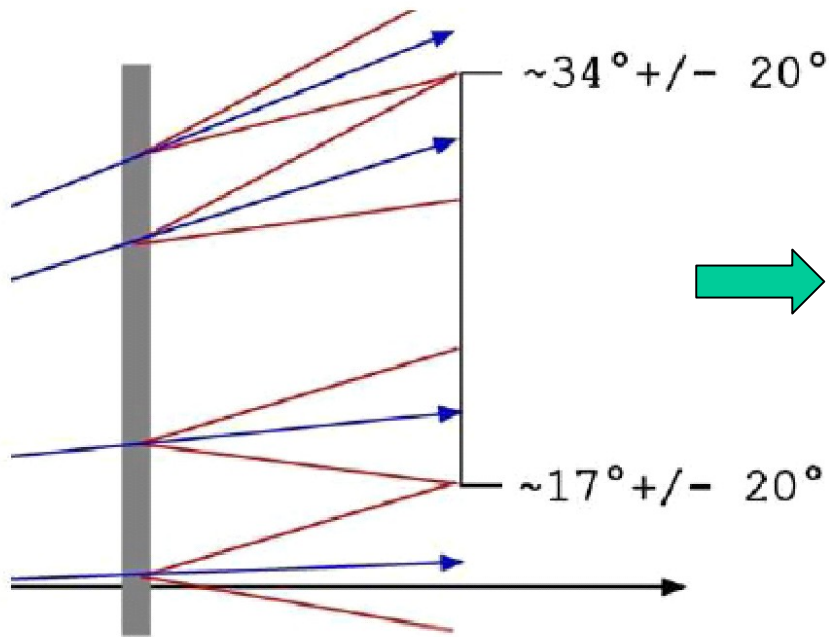
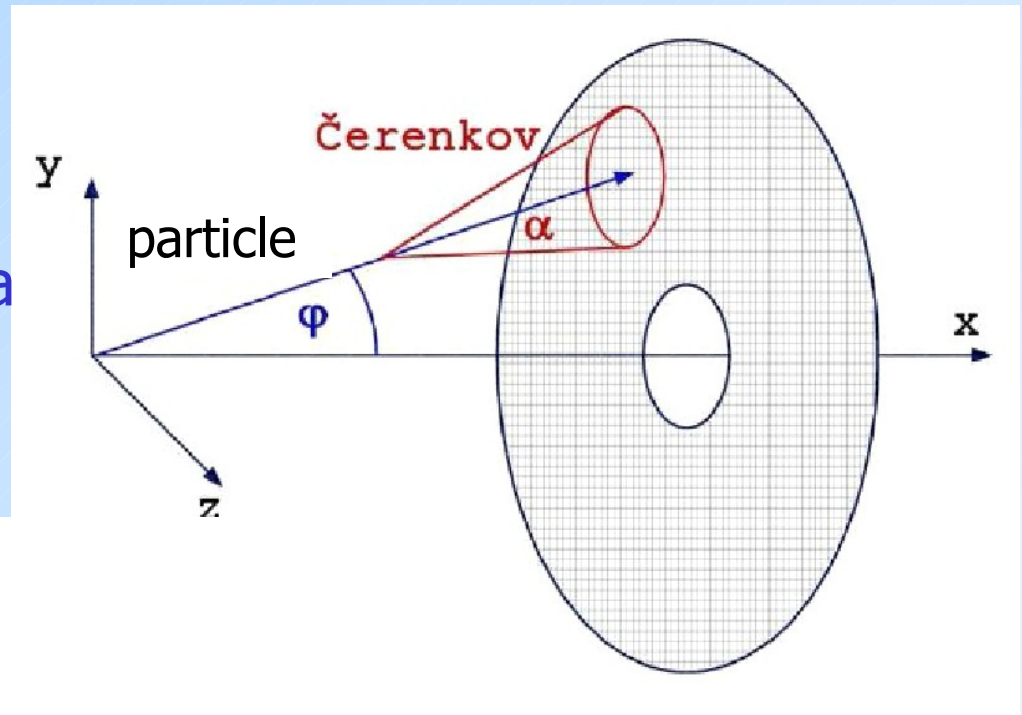

$\sim -3^\circ \dots 54^\circ$

→ Take this asymmetry into account when designing the light collection system.

Light collection: efficiency

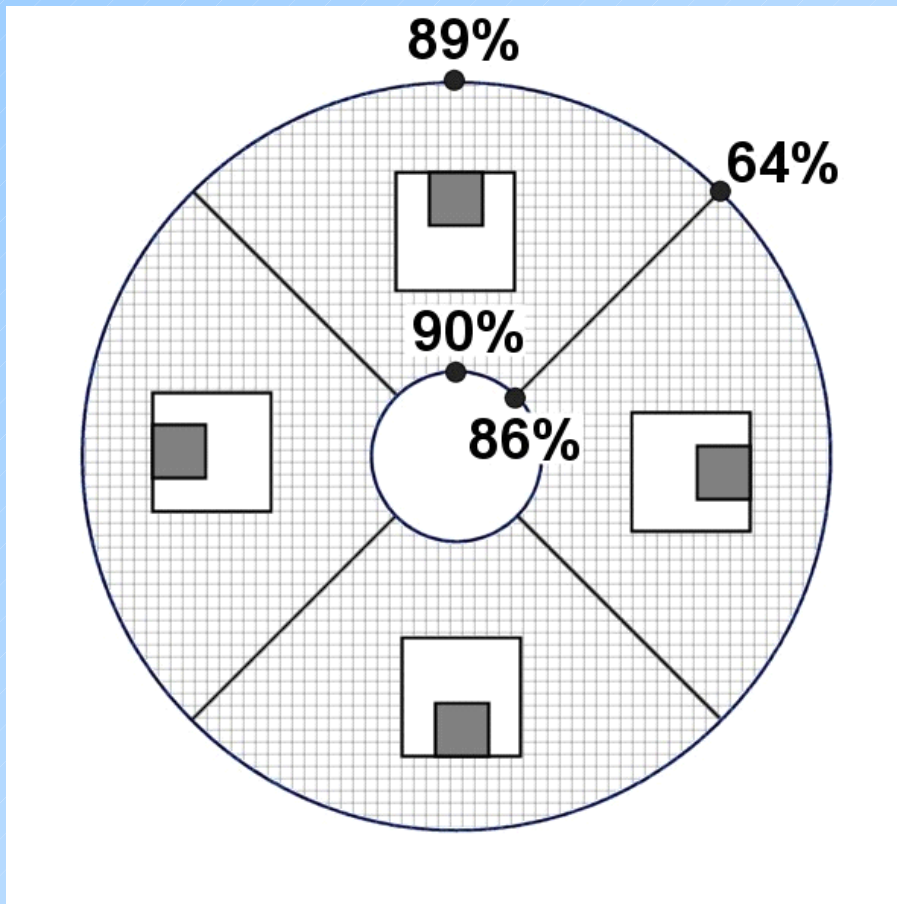

Design with a single light guide type

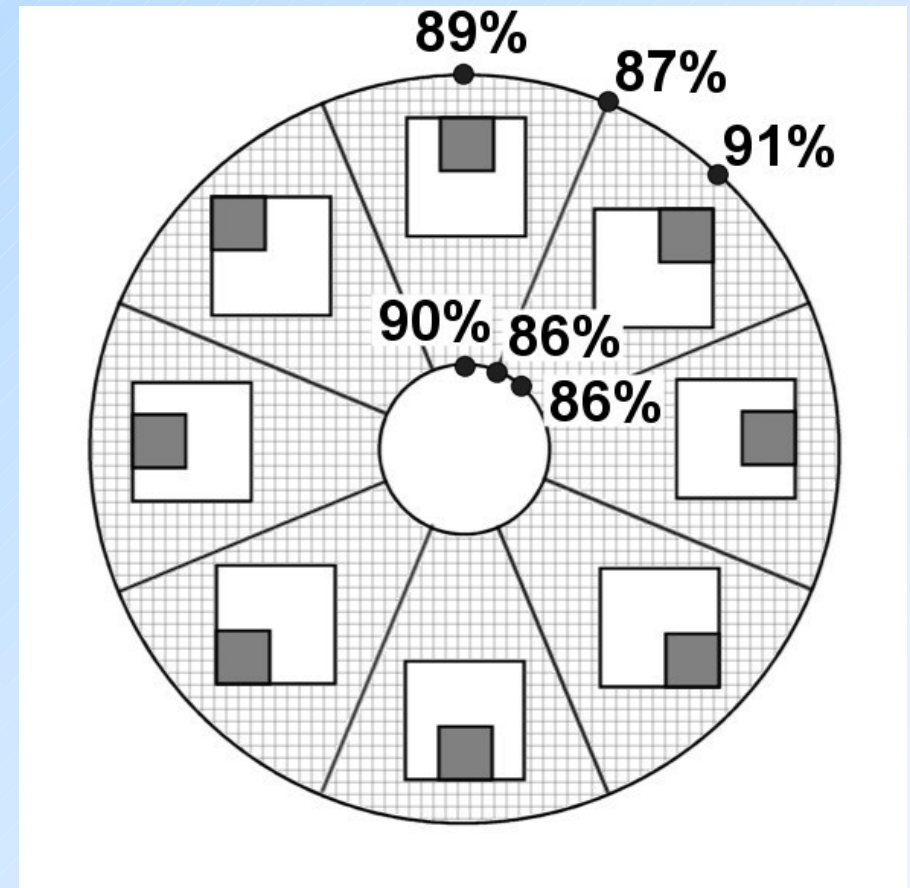

Design with a two light guide types

Summary and plan

- Module was constructed using 8x8 array of MPPCs (SMD package) and light guide array
- Proximity focusing RICH with 1cm aerogel radiator ($n=1.03$) and module was successfully tested in the pion test beam at CERN
- The number of detected photons per ring is about half of the expected number obtained using manufacturers PDE
- Efficiency increase with light guides ~ 2.3 (area ratio ~ 5.5)

Plan:

- Use waveform sampling electronics
- Improve LG production
- Tests in 1.5T magnetic field
- Check the radiation damage